

Laminex®

Architectural Wall Panels

Installation Guide



A proud
Australian
manufacturer

Contents

Section 1: Introduction	1
1.1 Purpose of this guide	1
Section 2: General information	2
2.1 Safety	2
2.1.1 Safety data sheet	
2.1.2 Personal Protective Equipment	
2.1.3 Tools and equipment	
2.1.4 Adhesives	
2.2 Handling	3
2.3 Storage	4
2.4 Packaging	5
2.5 Transport	6
2.6 Conditioning	6
2.7 Quality control	7
2.7.1 Inspection	
2.7.2 Technical data	
2.8 Care and maintenance	7
2.9 Warranty	7
Section 3: Applications	8
3.1 Interior	8
3.2 Exterior	8
Section 4: Design Guidelines	9
Section 5: Fabrication	11
5.1 Tools and Equipment	11
5.1.1 Consumables	
5.1.2 Workplace	
5.1.3 Cutting	
5.2 Checking wall to be square and plumb	12
5.3 Openings and cut-outs	14
5.3.1 General Power Outlets	
5.4 Skirting boards	16

Section 6: Installation	17
6.1 Planning	17
6.2 Fixing	19
6.2.1 Nails	
6.2.2 Z-Clips	
6.3 Expansion gaps and dimensional tolerance	22
6.4 Starting and finishing a wall	23
6.4.1 Choosing Installation Method	
6.5 Fixing to timber stud walls and/or steel framed walls	24
6.5.1 Preparing the wall	
6.5.2 Partial panel Installation	
6.5.3 Full panel installation:	
6.6 Fixing to brick and block walls or masonry	28
6.6.1 Preparing the wall	
6.6.2 Partial panel installation	
6.6.3 Full Panel Installation	
6.7 Fixing to plaster walls	32
6.7.1 Checking the wall	
6.7.2 Partial Panel Installation	
6.7.3 Full panel installation:	
6.8 Horizontal applications of Architectural Wall Panels	37
6.8.1 Planning join locations	
6.9 Installation of Architectural Wall Panels in High Humidity & Damp Areas	38
6.10 Use & fixing of dado rails and mouldings	41
6.11 Joining System	42
6.11.1 Corner Joins	
6.11.2 Corner Mouldings & Joins	

Section 1: Introduction

1.1 Purpose of this guide

This guide has been created to provide clear instructions required to successfully design and install Architectural Wall Panels. Adherence to the techniques and guidelines presented in this guide will ensure the finished article is compliant with the conditions of the product warranty.

Throughout this guide, the (w) symbol will appear against any specific instructions that are linked to compliance with the Laminex Architectural Wall Panels warranty.

This guide has been developed to allow designers, fabricators, and installers who work with Laminex Architectural Wall Panels to achieve performance standards for both domestic and commercial applications.

It is important to note that the techniques and guidelines presented in this guide are those recommended for use with Architectural Wall Panels. Any variation from these guidelines may create unexpected performance problems and may void the limited warranty.

This guide provides instructions to comply with the product warranty and is not intended to replace any testing you may need to conduct to determine the suitability of this product for your particular purpose and needs.

While every precaution has been taken in the preparation of this document, Laminex assumes no responsibility for errors omissions, or damages resulting from the use of information contained in this document. In no event will Laminex be liable for any loss of profit or any other loss or damage caused or alleged to have been caused directly or indirectly as a result of any person relying upon any information contained in this document.

Content in this guide is subject to change at any time without notice. Refer to the latest version of this document.

Panels should be installed with consideration to the Australian Construction Code – Building Code of Australia, Volume 1 and 2, and the relevant Australian Standards: **AS 3740:2021** Waterproofing of domestic wet areas, **AS 4386:2018** Cabinetry in the built-in environment Commercial & domestic.



Section 2: General information

2.1 Safety

Safety training, product knowledge, and product use are the responsibility of the installation facility tradesperson and employees.

Equipment selection, use, and maintenance are the responsibility of the installation facility tradesperson and employees.

Maintaining a clean and adequately ventilated workplace is the responsibility of the installation facility tradesperson and employees.

2.1.1 Safety data sheet

Refer to the latest version of the Safety Data Sheet (SDS) for this product.

2.1.2 Personal Protective Equipment

Always wear appropriate PPE when handling, cutting, or fabricating this product. Wear gloves, safety footwear, and suitable workwear apparel (no loose clothing or jewellery).



Gloves



Workwear



Boots

Occupational exposure to any type of dust is known to be hazardous to human health. Care must be taken to avoid the inhalation of dust. Follow good hygiene and workplace practices. Dust can be vacuumed or swept to avoid accumulation. If dust levels exceed Safe Work Australia Standards the wearing of a dust mask is recommended.



Dust Mask

If you intend to replace wall panels with Architectural Wall Panels:

- Ensure that the existing panels do not contain Asbestos. Consult and obtain professional guidance from licensed Asbestos removal services if required.
- If you are removing wall sheeting ensure your safety in relation to electrical cables, water and gas plumbing.

Always use safety glasses or approved eye protection and/or face shields when cutting, routing, and sanding. If dust levels exceed Safe Work Australia Standards the wearing of safety glasses is recommended.



Safety Glasses

2.1.3 Tools and equipment

Use and maintain all tools and equipment in accordance with the manufacturer's instructions.

Keep all equipment safety guards and dust collection devices in place.

2.1.4 Adhesives

Always refer to the manufacturer's Technical Data Sheet (TDS) and Safety Data Sheet (SDS) for instructions on how to store and use solvents, adhesives and other materials in a safe manner

2.2 Handling

This panel weighs approximately 17.8-19.3kg/m². It's important to handle the panels with care during lifting. Whenever possible, carry full panels vertically to minimize flexing or the risk of breakage. Additionally, ensure that panels are lifted from the non-routed face to prevent damage. Refer to the table below for size and weight.

PROFILE	PANEL SIZE (MM)	WEIGHT KG/M ²
Batten 40	3000 x 578mm	19.3
Batten 60	3000 x 558mm	18.9
Vgroove 100	3000 x 518mm	17.8

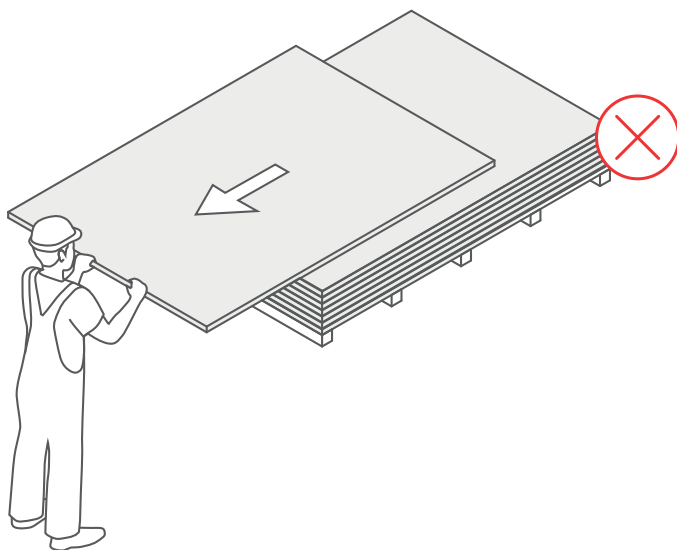

- Ⓜ If moving or transporting panels via forklift or suction lift, move panels carefully to avoid damage and ensure the right fork length is used for the panel size. Do not overload the forklift.

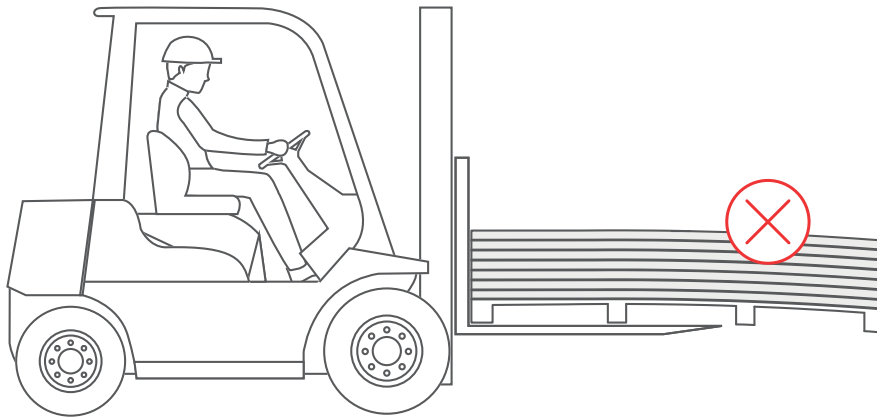

- Ⓜ **DO NOT** slide panels over one another to move them.
- Ⓜ Always gently lift and place the panels to avoid damage to the decorative surface.

2.3 Storage

- Ⓜ When working with loose panels of Architectural Wall Panels, where the original packaging is removed, the panels must be stored horizontally in a flat level fully supported manner. Place a protective cover over the unused panels.
- Ⓜ Packs must be stored on a level horizontal surface and aligned with each other.
- Ⓜ Material must be stored in a dry, fully enclosed area away from exterior doors. Do not leave the Architectural Wall Panels in the rain, and wind, and protect from UV light.
- Ⓜ **DO NOT** store Architectural Wall Panels within areas where newly poured concrete or wet plastering is present.
- Ⓜ When working from a pack of Architectural Wall Panels, use panels as required and place a protective cover over the unused panels.

- Ⓜ Do not store product on pallets with bearer spacings more than 600mm apart.

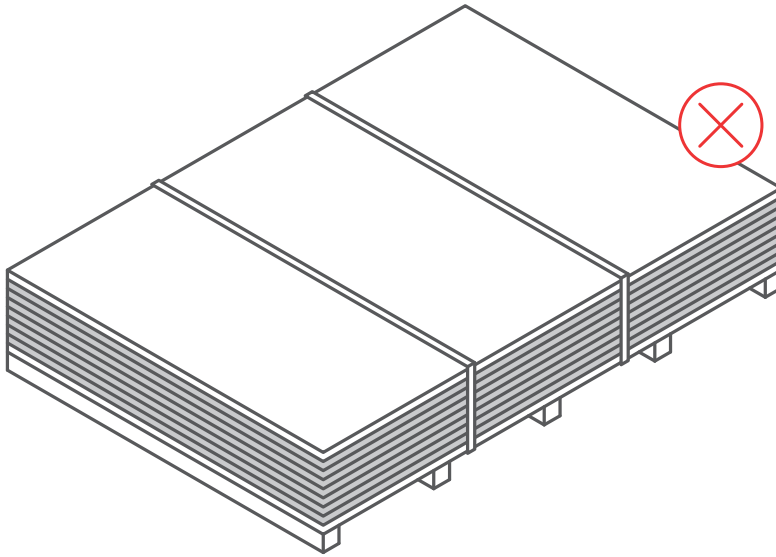

- Ⓜ Do not stack more than three packs high.

- Ⓜ Do not stack different-sized packs on top of each other.

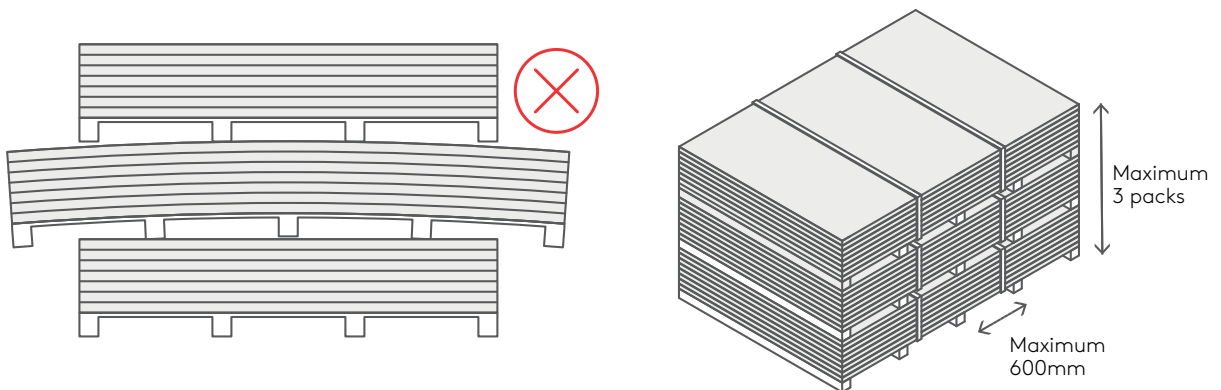

2.4 Packaging

The use of suitable packaging is essential to controlling and maintaining equilibrium moisture content (EMC). An imbalance of moisture will result in bowing or warping of the material.



2.5 Transport

It is important to take precautions when transporting Laminex Architectural Wall Panels. Ensure product surfaces and edges are well protected when transporting, storing, fabricating, and installing panels.

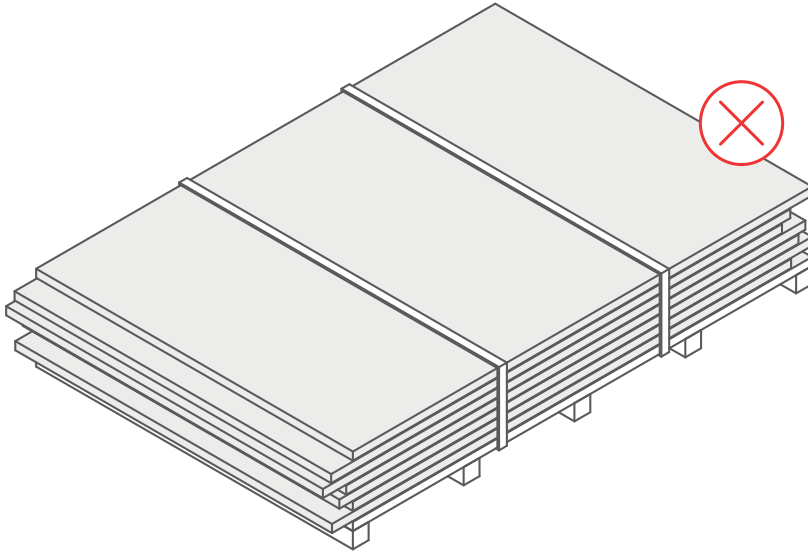

All straps and restraint devices must remain grit and burr free and suitably tensioned to prevent movement of the product during transport. Covered loads are recommended to prevent damage during transport to the site.

Ⓜ | During transportation, use flat, stable supports of at least the same dimensions as the material.

2.6 Conditioning

Pre-conditioning of Architectural Wall Panels is required to achieve equilibrium moisture content (EMC) before fixing, to reduce the likelihood of bowing or shrinkage after installation.

Therefore, Architectural Wall Panels must be stored for a minimum period of 48 hours at the same environmental conditions as the subsequent place of use, preferably in the room where the panels are to be installed.

Failure to condition material may result in product expansion and contraction in response to environmental conditions, particularly with changes in temperature and humidity. This may result in, but is not limited to, bowing or warping of panels, joint failure or build-up of internal stresses that release in the form of cracks.

Architectural Wall Panels must be installed in locations where environmental conditions can be controlled and maintained in a manner that avoids large fluctuations in temperature and humidity.

Ⓜ | Failure to adhere to conditioning guidelines will void your warranty.



Failure to maintain and control the temperature and humidity of installation environments will void your warranty.

Timber structures to which Laminex Architectural Wall Panels are fixed will also respond to changes in the humidity and temperature of the surrounding environment. Hence, temperature and humidity must be effectively controlled to minimize fluctuations in moisture content. Inadequate control of these parameters may result in the expansion or contraction of the framing.

2.7 Quality control

2.7.1 Inspection

ALL panels must be visually inspected prior to the commencement of **ANY** cutting or installation.

Before commencing any cutting or installation, the following must be checked:

- Correct items (thickness, profile design, etc)
- Consistent profiled design (ensure panels for the same installation are inspected for profiled design compatibility)
- Inspect for defects, such as: chips, scratches, evidence of transport damage, general quality of the surface finish and quality of the edge.

Inspect the Architectural Wall Panel Invislock joints and ensure they are not damaged.

If products are believed to be defective, record all order details and contact your Laminex representative as soon as possible.



Once cut or installed, no claims for visual defects will be recognized.

2.7.2 Technical data

Refer to the latest version of the Technical Data Sheet (TDS) for this product.

2.8 Care and maintenance

Refer to the care and maintenance for Architectural Wall

2.9 Warranty

Architectural Wall is covered by a 10-year limited warranty.

Refer to the latest version of the warranty for this product.



Section 3: Applications

3.1 Interior

- Ⓜ | Architectural Wall Panels are **ONLY** suitable for interior wall panel applications.
- Ⓜ | Architectural Wall Panels are **NOT** suitable for any ceiling or floor applications. Refer to the Architectural Ceiling Panels and Tiles for ceiling application.
- Ⓜ | If the Architectural Wall Panels are used in a bathroom, kitchen, or laundry, local waterproofing requirements must be met according to the guidance in section 6.9.
- Ⓜ | Architectural Wall Panels must **NOT** adhere to tiles, cork, natural stone, textiles, wallpaper, timber paneling or Masonite.

3.2 Exterior

- Ⓜ | Architectural Wall Panels are **NOT** suitable for use in any exterior applications.

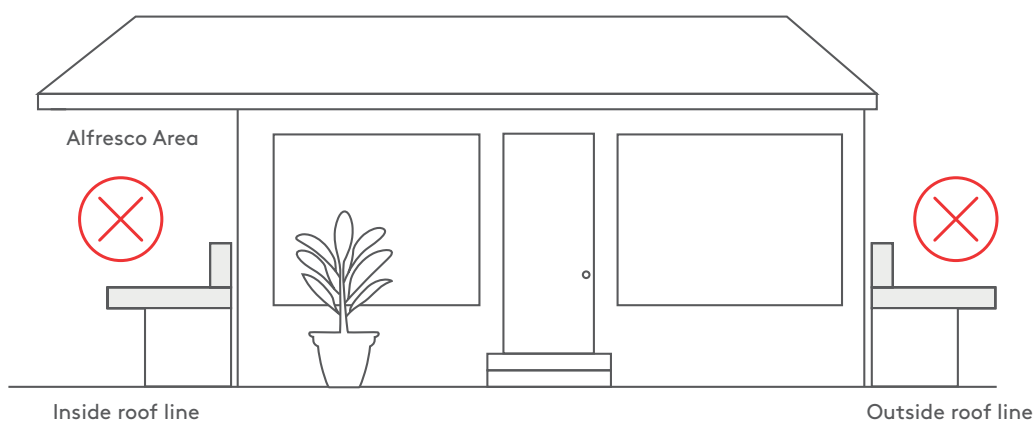

Section 4: Design Guidelines

When you are in the planning and design stage of your project there are some important points to consider ensuring your installation meets the compliance requirements for the Architectural Wall Panels warranty.

Key considerations for your Architectural Wall Panels project include both aesthetic detailing and the planning of the location or room in which the panels are to be installed.

Architectural Wall Panels are unsuitable for use in any external applications.

For wet areas follow the installation instructions in the guide. The panels should not be applied to sliding doors or internal honeycomb construction doors. Ceilings and floors are unsuitable applications for Architectural Wall Panels (see guidelines for Laminex Architectural Ceiling Panels and Tiles). Non-compliant use of panels will not be considered under warranty.

You should ensure that project specification documents include installation instructions and should follow all technical requirements of the Architectural Wall Panels installation guide.

Wall suitability is important for the successful installation of Architectural Wall Panels. Minor modifications to studs and wall frames may be required.

Your project design checklist should include consideration of the following:

- Position of existing or planned windows, doors and openings, GPO's, light and fan controls, air conditioner vents and other cut-outs through the panel for functional appliances.
- Will full-height panels be used or are partial-height panels required? Partial wall height panels may require additional reinforcement and/or wall modifications to be used for support of the top and bottom of the panel.
- Expansion joints must be maintained between elements such as floors, ceilings, architraves, skirtings, fixtures and fittings.
- When selecting the design direction of the Architectural Wall Panels, consider the direction carefully. Always utilize the Invisilock™ join for joining panels together. Avoid butt joining of panels as it is not recommended and is not covered by warranty.
- Minimum distances from the edge of Architectural Wall Panels must be maintained for items to be cut in. Any access cut-outs for GPO (electrical outlets), air conditioning vents, light switches, or similar, must not be located less than 150mm from the edge of the Architectural Wall Panel.
- Consideration of the specific design of the Architectural Wall Panels selected for use and the surface of the intended walls. Is the scale and directionality of the design a good fit for both the uninterrupted areas of the project as well as the areas that might involve multiple cut-outs around fixtures and fittings or change of direction through internal and external corners?



- If more than one design of the Architectural Wall Panel is considered for the project, the appearance of the panels in both the height and the width of the wall is important. The use of different designs together is recommended with the addition of a dado rail applied along the interface join between the two patterns.
- Mouldings, architraves and dado rails: If the use of mouldings and dado rails is anticipated, consider the location on the wall. Will they be interrupted by architraves on windows/doors and what is the optimum height to achieve an unbroken line?

Effective width and Overall width

PROFILE	LENGTH(IN MM)	EFFECTIVE WIDTH(MM)	OVERALL WIDTH(MM)
Batten 40	3000	560	578
Batten 60	3000	540	558
V-Groove 100	3000	500	518

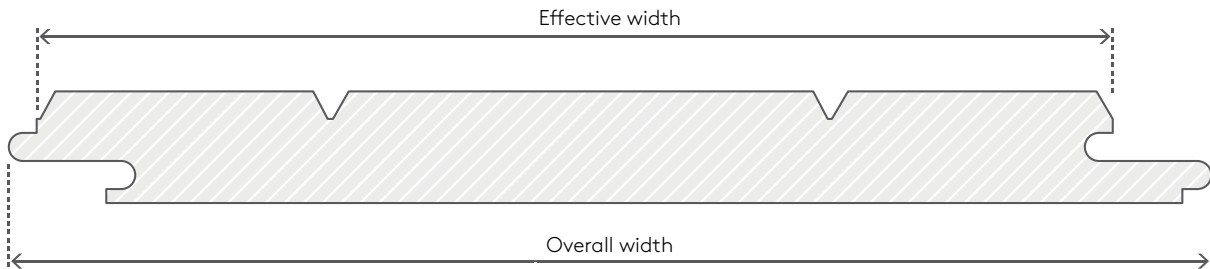
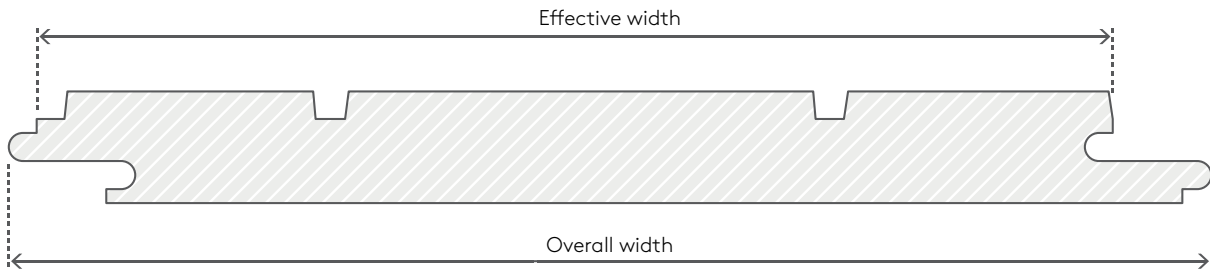

Section 5: Fabrication

5.1 Tools and Equipment

This is not an exhaustive list, but it is recommended that the following be checked and available:

- Tape Measure
- Spirit Level
- String Line or equivalent
- Power Saw
- Tugstone Carbide TCT (triple chip blade) 72+ teeth
- Hammer and/or Nail Gun or Screw Gun
- Pencil or chalk for marking out
- Caulking gun
- Sanding sponge
- Protective Equipment (PPE)

5.1.1 Consumables

- Nails to hold glued joints together until the adhesive has set. The nail fixings used should be twice as long as the material they are fixing. A 16G nail is recommended to prevent splitting of the Invisilock™ join.
- Flexible construction adhesive to be used to glue the panels to the plaster wall, frames or studs and noggins. Ensure that the adhesive permits a 25% movement capability.
- PVA adhesive is recommended for gluing corners together and supporting moulding such as dado rails in place before fixing.
- Sealants and/or Gap Fillers to be used when fixing other trims such as timber mouldings skirtings and cornices. A 25% movement capability and paintable finish are required.
- Spacers for the expansion gap
- Timber-based filler to fill nail/screw holes.

5.1.2 Workplace

Keep the work area clean, uncluttered, and well lit.

Avoid panel contact with abrasive surfaces, grit or other processing debris. Contamination trapped between panels will cause surface indentations, marring or scratching.



Avoid contact with solvents, moisture and oil which can contaminate the panels and affect the performance of adhesives and coatings.

When cutting panels ensure that the full panel is well supported before any cutting or processing.

5.1.3 Cutting

Please ensure all parties using cutting equipment are suitably trade qualified or experienced in the use of these tools. All safety guards supplied with the equipment should be maintained and tools should be inspected before use including electrical cords and plugs in good working order. Please follow the safety procedures supplied by the manufacturer of the tools employed.

Incorrect use of cutting tools and failure to use appropriate caution can result in substantial injury. Only proceed once safe working conditions have been established.

Architectural Wall Panels can be readily cut with a power saw. New or sharpened blades should always be used as blunt or dull blades will decrease the accuracy and finish of cuts. It is recommended to use Tungsten Carbide TCT or diamond tip blade.

We recommend the use of power saws that have an additional scribing blade to prevent chipping of Architectural Wall Panels.

Handsaws are not recommended for working on this 16mm thick material. Powered tools are more successful due to thickness and avoidance of the chip-out of the decorative face.

Direction of the cutting and orientation of the board (decorative face up or decorative face down) is dependent on the power tool/blade selected for use. It is recommended where scribing blades are used to cut the panel with the decorative face up. Circular saws without scribing blades would be typically suitable to cut the panels with the decorative face down.

It is recommended that a test piece be cut to verify the correct decorative face position for the specific cutting equipment to be used.

If using a router, do not allow the cutter to take too deep a cut at a time and only trench a maximum of one-third of the thickness, per pass.

5.2 Checking wall to be square and plumb

Check Wall Plumbness:

Position the spirit level against the wall in a vertical orientation.

Ensure the level is aligned straight up and down.

Observe the bubble at the spirit level. It should be centred between the two lines if the wall is plumb.

If the bubble is not centred, note the direction and the degree of the tilt.

Use a pencil or marker to indicate areas that are out of plumb.

Repeat the process at various points along the wall to identify any inconsistencies.

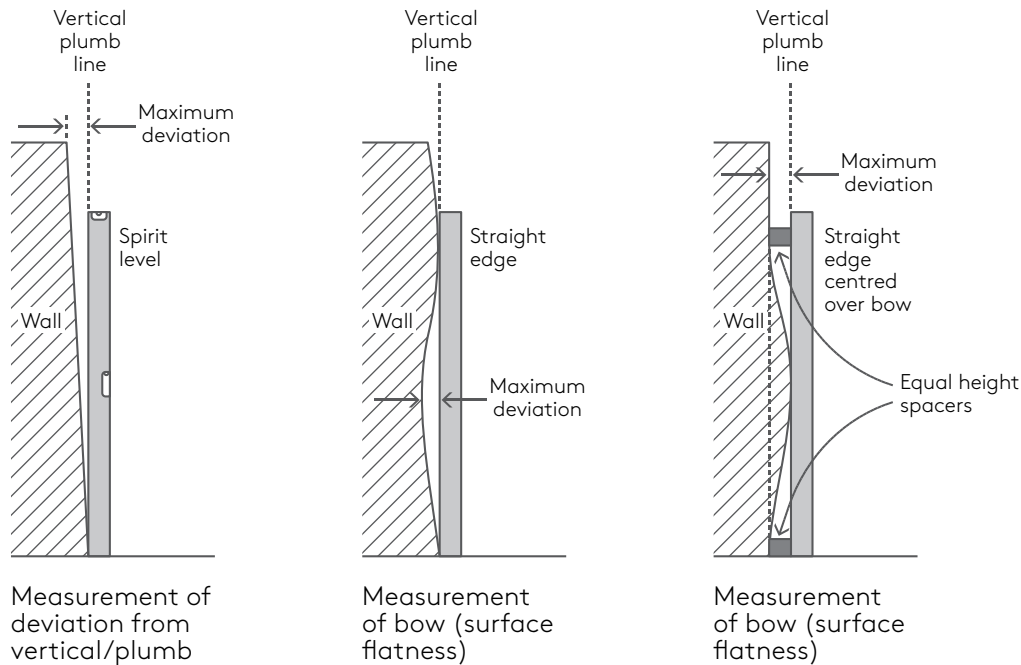

Check Wall Squareness:

It is important to check intersecting walls when joining the Architectural Wall Panel at internal and external corners.

Position the carpenter's square in one corner of the area.

Ensure one side of the square aligns with one wall and the other side aligns with the adjacent wall.

Look for any gaps between the square and the wall surfaces.

If there are no gaps and the square fits snugly into the corner, the walls form a 90-degree angle and are square.

If there are gaps, the walls are not square.

Perform this check at all corners of the area to ensure overall squareness.

It is important to check the intersecting wall.



5.3 Openings and cut-outs

Measure the location of any openings and cut-outs to be performed on the decorative face. Apply masking tape on the decorative face where cut-outs are to be performed to assist in minimizing the chip-out. Any internal corner or aperture must be cut with a minimum internal radius of 10mm.

All edges must be smooth and free of damage, cracks, dents or notches.

Seal all openings and cutouts of the Architectural Wall Panels. Use a brushable sealer e.g. Cabot's Cabothane clear water based polyurethane.

- Ⓜ Cracks or any other failure attributable to non-compliant openings or cut-outs will not be recognized under warranty.

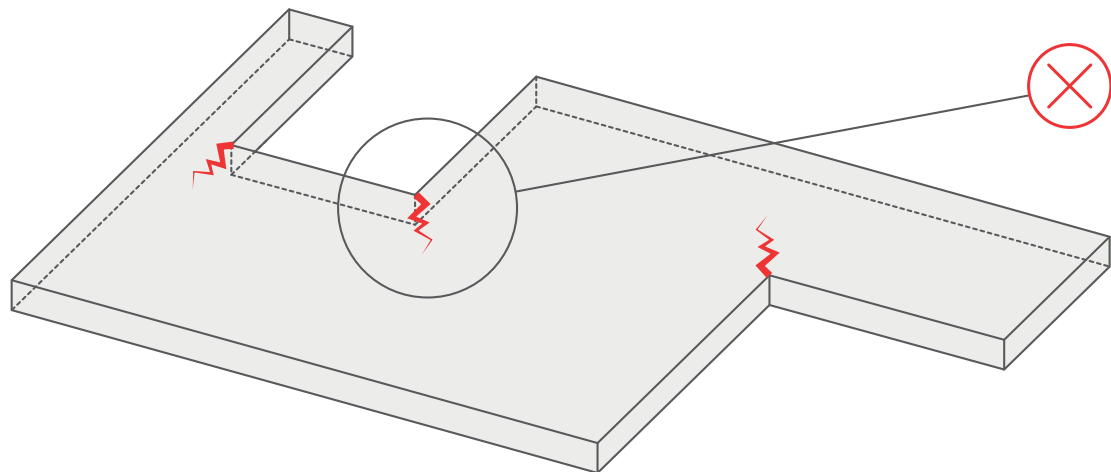
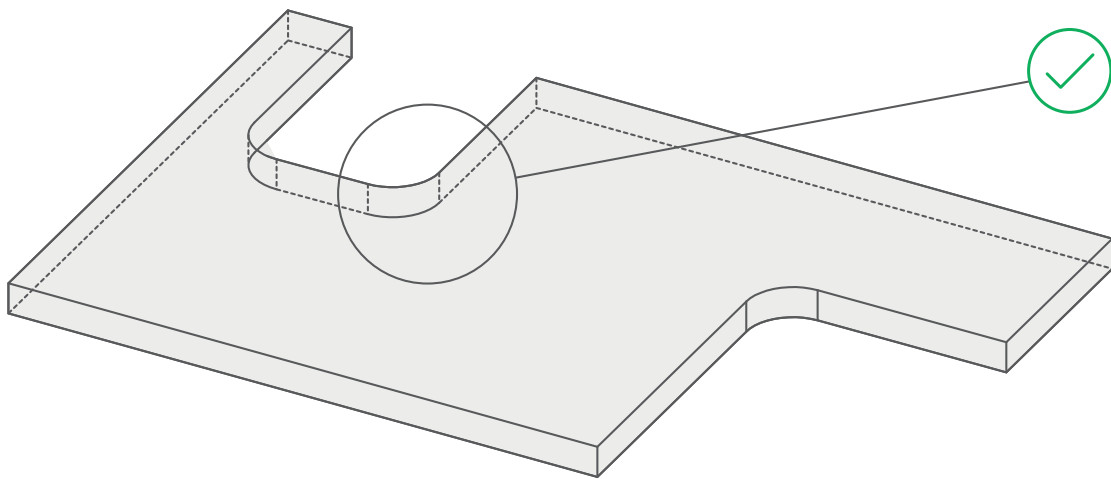

Cut-outs can be made with a router or by pre-drilling a hole with an appropriate diameter drill bit to meet internal radius requirements and then cutting between drill holes.

Any access cut-outs for GPO (electrical outlets), air conditioning vents, light switches, or similar, must not be located less than 150mm from the edge of the Architectural Wall Panel

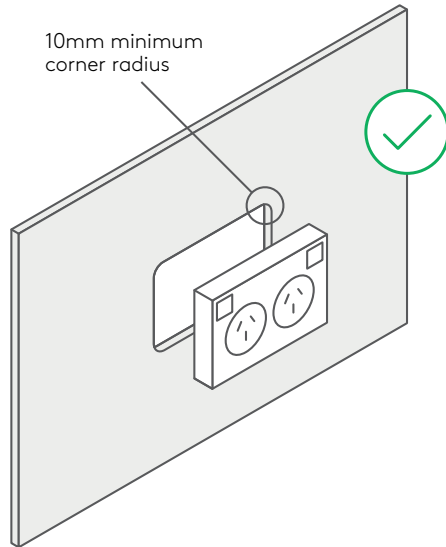

5.3.1 General Power Outlets

For flat profiles it is recommended to fix the GPO to the front face of the panel.

Once installed it is important to fill in any spaces at the back of the GPO to ensure dust and moisture do not have access to the back of the outlet.

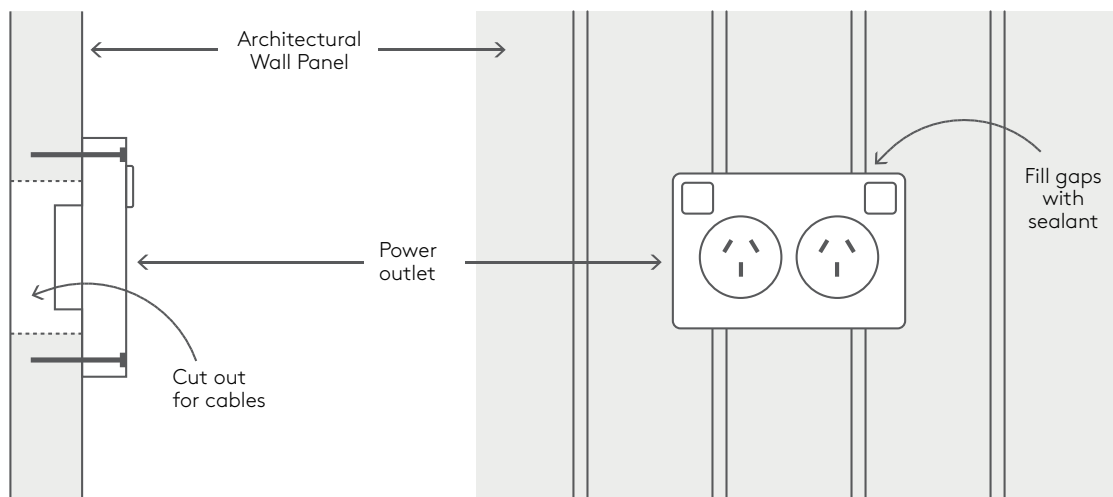

5.4 Skirting boards

You can hide the expansion gap by installing a skirting board on top of the Architectural Wall Panel. When doing this, it is important to include a spacing block in between the skirting and frame.

Add a trim to finish the panel installation. This can be achieved by attaching an L angle trim to the rear of the panel. By doing so, it will allow for any expansion that may occur.

Finish your wall by installing a skirting board to the bottom of the wall, allowing room for an expansion gap. You can then fill the expansion gap with caulking to create a smooth complete look.

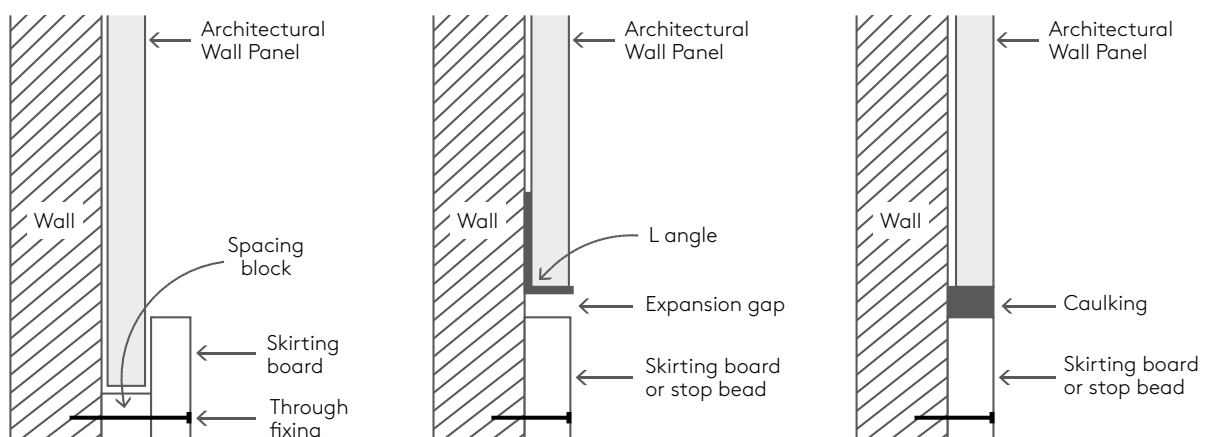

Section 6: Installation

6.1 Planning

Before starting your project using Architectural Wall Panels, it is important to identify some key attributes of the area in which the material will be placed and to plan the installation of the panels.

Wall type

What kind of wall are the panels to be affixed to? Is it fitted onto masonry/brick, steel, or timber frames, or are the panels to be used over existing plaster walls? These considerations will inform which fixing method is appropriate, what preparation may be required to prepare the space, and the tools required.

Openings and cut-outs

How many windows or doors openings appear within the project? Take note of any requirements to cut in GPO outlets, air-conditioning vents or other similar attributes that will require panels to be pre-cut before fixing to the wall.

Internal and external corners

Planning for the joining of panels and the overall layout will include noting where panels may be applied around an internal or external corner.

Full-height panels or part-height panels

Will full-height panels be used or are part-height panels for the balance of the wall, to be considered?

Mouldings and dado rails

If the use of mouldings and dado rails is anticipated, how high up the wall they are to appear, will they be interrupted by architraves on windows or doors and what is the optimum height to achieve an unbroken line where practical, are all recommended considerations in the planning of the project.

Mixing Architectural Wall Panels on a wall

If more than one design of Architectural Wall Panels is considered for the project, the appearance of the panels in both the height and the width of the wall is important. The use of different decors together is recommended with the addition of a dado rail applied along the interface join between the two patterns.



Measuring your space

For the success of any project involving wood-based materials, it's essential to measure twice and cut once. Accurate measurements are crucial for ordering the correct panels and accessories. When estimating the quantity of Architectural Wall Panels needed, ensure to account for expansion gaps of 10mm adjacent to any fixtures.

Prepare your panels

Architectural Wall Panels are made from Medium Density Fibreboard (MDF). MDF responds to the humidity and temperature of the surrounding environment, affecting the moisture content of the product and resulting in panel dimensional change.

All Architectural Wall Panel edges, including cutouts for pipes and tapware, must be sealed appropriately and effectively to prevent moisture ingress.

Architectural Wall Panels need to acclimatize for a minimum of 48 hours onsite before installation. This should be integrated into the ordering, delivery, and project planning.

Effective width and Overall width

PROFILE	LENGTH (IN MM)	EFFECTIVE WIDTH (MM)	OVERALL WIDTH (MM)
Batten 40	3000	560	578
Batten 60	3000	540	558
V-Groove 100	3000	500	518

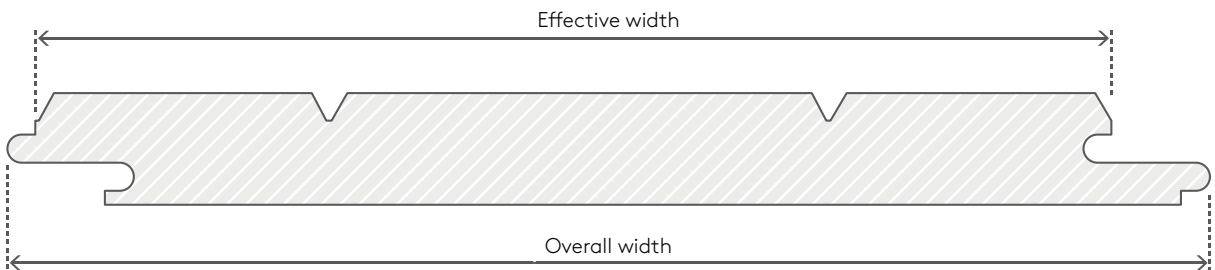
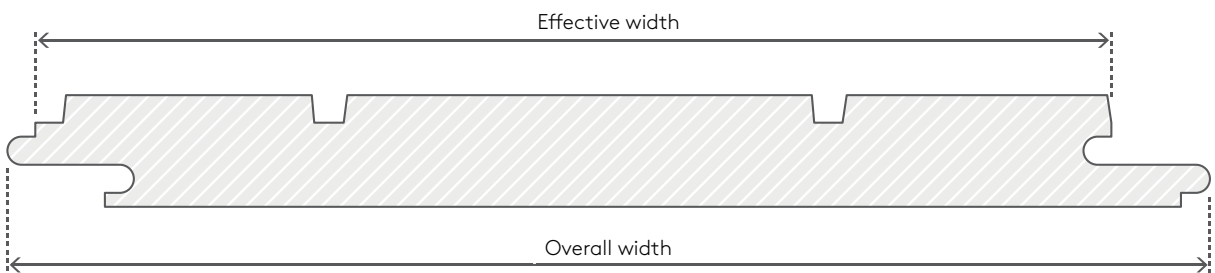

6.2 Fixing

Fixings should be carefully positioned to prevent splintering and breakout.

No face fixings are allowed on the decorated face.

Fixings are to be located at 10mm from the edge of the Invisilock™ join.

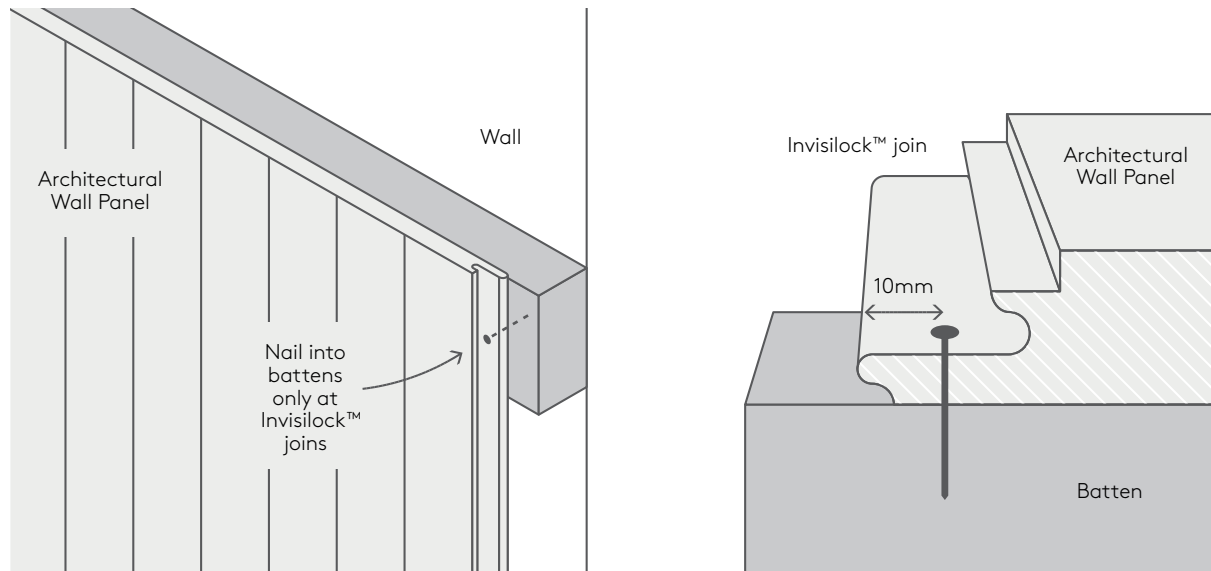

When applying fixings with power tools (nail gun) only use enough pressure to drive the head of the nail or screw marginally below the surface of the panel. Splitting of the panel can occur if the pressure is too high.

6.2.1 Nails

Finishing nails offer superior holding power than smooth nails. Driving nails in at an angle further enhances the holding capacity.

The type of brad nail used to secure the panel should be carefully chosen to withstand the environmental conditions and the size of the batten or support structure. In applications where there is a possibility of high ambient humidity, it's essential to use corrosion-resistant nails. The selection of brad nails must also consider the batten or support structure.

AS 3566.2-2002 Self-drilling screws for the building and construction industries; General requirements and mechanical properties outlines four levels of corrosion resistance. Additionally, **AS 2334-1980 Steel Nails – Metric Series** provides guidance on the requirements for nails and fixing.



For applications requiring high corrosion resistance, stainless steel brad nails are available, meeting the highest performance standard (**AS 3566.2-2002** Class 4).

APPLICATION		
Class 1	General Environments	Bright Steel
Class 2	Significant Humidity	Electro Galvanized
Class 4	Treated Timber or Premium Corrosion Resistance	Stainless Steel

These classifications outlined in **AS 3566.2-2002** guide the corrosion resistance protection type suitable for different environmental conditions types.

6.2.2 Z-Clips

Fixing Z clip on the wall

Ensure the wall surface is clean, flat, and free from any debris or obstructions.

Ensure the appropriate Z-clip system according to the weight of the Architectural Wall Panel.

Determine the desired height and layout for the Z-clips on the wall.

Use a pencil or marker to mark the locations on the wall where each Z-clip will be installed.

Ensure the spacing between each Z-clip is 450mm and/or within the allowable range specified for your specific application.

Position the first Z-clip at the marked location on the wall, aligning with the marked mounting point.

Secure the Z-clip to the wall using appropriate fasteners (such as screws) according to the manufacturer's recommendations.

Repeat this process for each Z-clip, ensuring they are installed at the designated locations with consistent spacing.

If any adjustments are needed to ensure proper alignment or spacing, carefully loosen the fasteners and reposition the Z-clips as required.

Installing Z Clips on Architectural Wall Panel

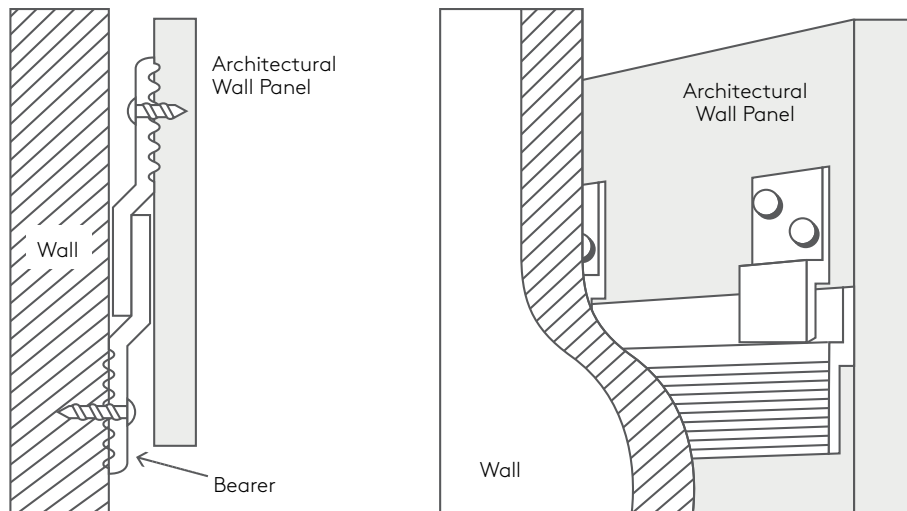

Ensure the Architectural Wall Panel is clean, flat, and free from any debris or obstructions.

Determine the desired orientation of the panel and mark the locations for attaching the Z-clips on the backside of the panel.

Use a pencil or marker to mark the locations on the backside of the Architectural Wall Panel where each Z-clip will be attached.

Ensure the spacing between each Z-clip is equal to the Z-clips mounted on the walls.

Position the first Z-clip at the marked location on the backside of the panel, aligning it with the marked mounting point.

Secure the Z-clip to the panel using appropriate fasteners (such as screws) according to the manufacturer's recommendations.

Repeat this process for each Z-clip, ensuring they are attached to the panel at the designated locations with consistent spacing.

Mounting the Architectural Wall Panel

Position the panel against the wall at the desired location, ensuring it is level and aligned properly.

Carefully lift the panel and slide the Z-clips on the backside of the panel into the corresponding Z-bar or mounting brackets attached to the wall.

Once the Z-clips are engaged with the Z-bar or mounting brackets on the wall, carefully lower the panel to secure it in place.

Ensure the panel is securely attached to the wall and does not wobble or shift.



6.3 Expansion gaps and dimensional tolerance

Wall-to-floor interface

A minimum expansion gap of 10mm **MUST** be left between the top surface of the primary floor and the bottom edge of the Architectural Wall Panels. Fixings of moulding/wall skirtings must maintain the unimpeded 10mm gap.

Wall-to-ceiling interface

A minimum expansion gap of 10mm **MUST** be left between the top edge of the Architectural Wall Panels panel and the primary ceiling. Fixings of a cornice or moulding must maintain the unimpeded 10mm gap.

DO NOT "Hard Knock" adjacent panels into position.

Panel to fixture interface

A fixture is defined as any permanent structure affixed to the wall or ceiling, including architraves. A minimum expansion gap of 10mm **MUST** be left between the edge of the Architectural Wall Panel and the fixture.

Full run wall expansion allowance

An allowance of a 10mm expansion gap between every set of 10 panels **MUST** be provided. This can be achieved using express joints or shadow lines, as needed.



Any expansion gap allowance non-compliance will not be recognized under warranty.

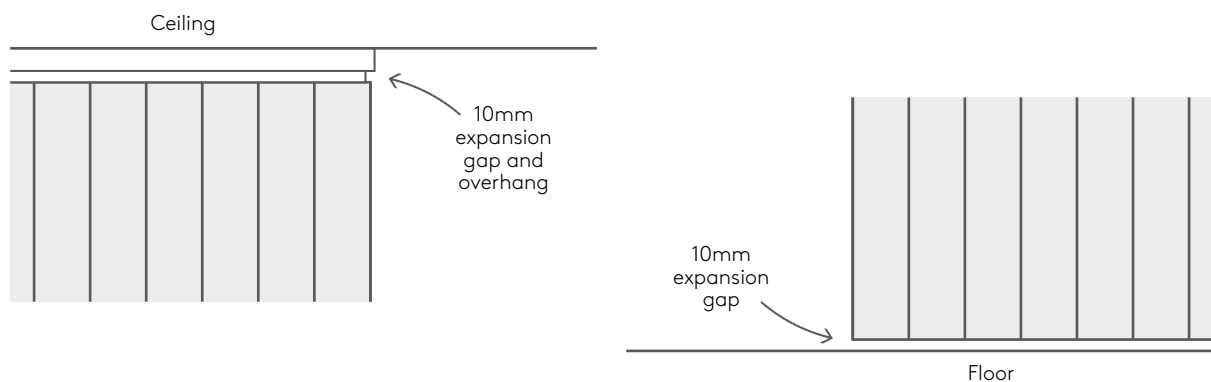

Fill all expansion gaps between panels and fixtures with the flexible sealants with minimum 20% movement capability to prevent moisture ingress.

6.4 Starting and finishing a wall

There are two recommended methods for installing the panels:

Partial panel installation method: This method involves achieving uniformity at the start and end of the wall by cutting a partial strip at the beginning and end of the wall installation.

Full panel installation method: This method entails installing full panels from the start to the end of the wall.

The method you choose will depend on the size and design of the wall.

6.4.1 Choosing Installation Method

To determine the number of panels needed, measure the wall and divide the total wall width by the effective width of the panels. These panels can be used in full size without cutting or if the partial panel method is selected, cut one panel vertically at the width required for your partial starting panel.

For example, if the wall width is 3000mm and the effective width of the panel is 500mm, you would need 6 full panels ($3000/500 = 6$).

After determining the number of panels required, consider which installation method is applicable according to the wall type, refer to section 6.5, 6.6 and 6.7 for more information:

Effective width and Overall width

PROFILE	LENGTH (IN MM)	EFFECTIVE WIDTH (MM)	OVERALL WIDTH (MM)
Batten 40	3000	560	578
Batten 60	3000	540	558
V-Groove 100	3000	500	518

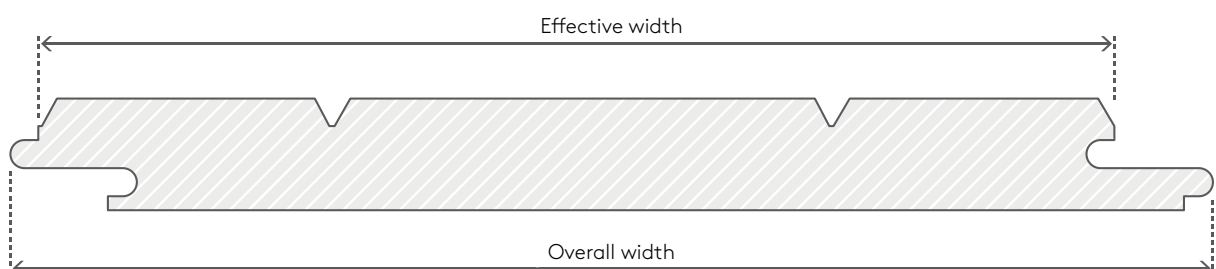
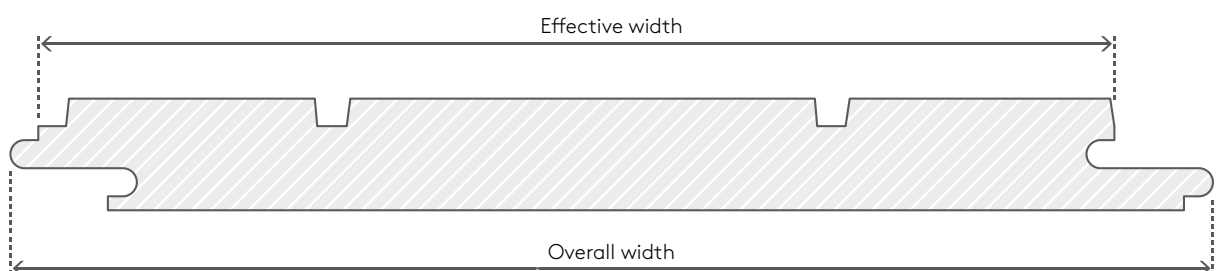

6.5 Fixing to timber stud walls and/or steel framed walls

6.5.1 Preparing the wall

Battens should be attached as the fixing system to the stud or steel frame, using nails or power-driven fasteners according to the instructions provided with the fixings.

The fixing system should be fitted horizontally at a minimum of 450mm centers to promote airflow behind the Architectural Wall Panels.

If Architectural Wall Panels are to be used for partial wall height installations, place battens just below the top edge of the panel for support.

Check that the fixing system is square and plumb. Refer to section 5.2 for the process.

Any amendment to a frame required to rectify irregularities must be conducted by a qualified tradesperson.

Please refer to and comply with all expansion gap requirements.

6.5.2 Partial panel Installation

After completing the measuring steps in section 6.4, cut your first partial starting panel with a max 250mm effective width to be fixed at the start of the wall.

Start from one corner/edge of the wall and work across.

Apply construction adhesive on each batten/furring channel behind each Architectural Wall Panel. It is recommended to follow the adhesive manufacturer's instructions for the amount to be used.

Position the panel on the wall, ensure there is a 10mm expansion gap at the wall-to-floor interface.

Spacers can be used as a removable prop to lift the Architectural Wall Panel off the floor.

Ensure there is a 10mm expansion gap at the wall-to-ceiling interface.

Use a spirit level to ensure the Architectural Wall Panel is accurately placed onto the frame. Refer to section 5.2 to check wall is square and plumb.

Using nails or power-driven fasteners, fix the panels to the battens.

Position mechanical fasteners at 10mm from the edge of the Invisilock™ join of the panel on each batten working from the center out or top to bottom fixing pattern.

Remove the spacer from the bottom of the Architectural Wall Panel.

The next panel can now be placed into position using the Invisilock™ join to align the joins.

DO NOT hard knock panels together.

Fix the other panels using the same method outlined above, working along the wall from the first panel.

As you approach a corner or doorway, measure the gap from the fixed panel to the corner (effective width) and cut the next panel to fit the remaining space. It is important to maintain the expansion gap throughout.

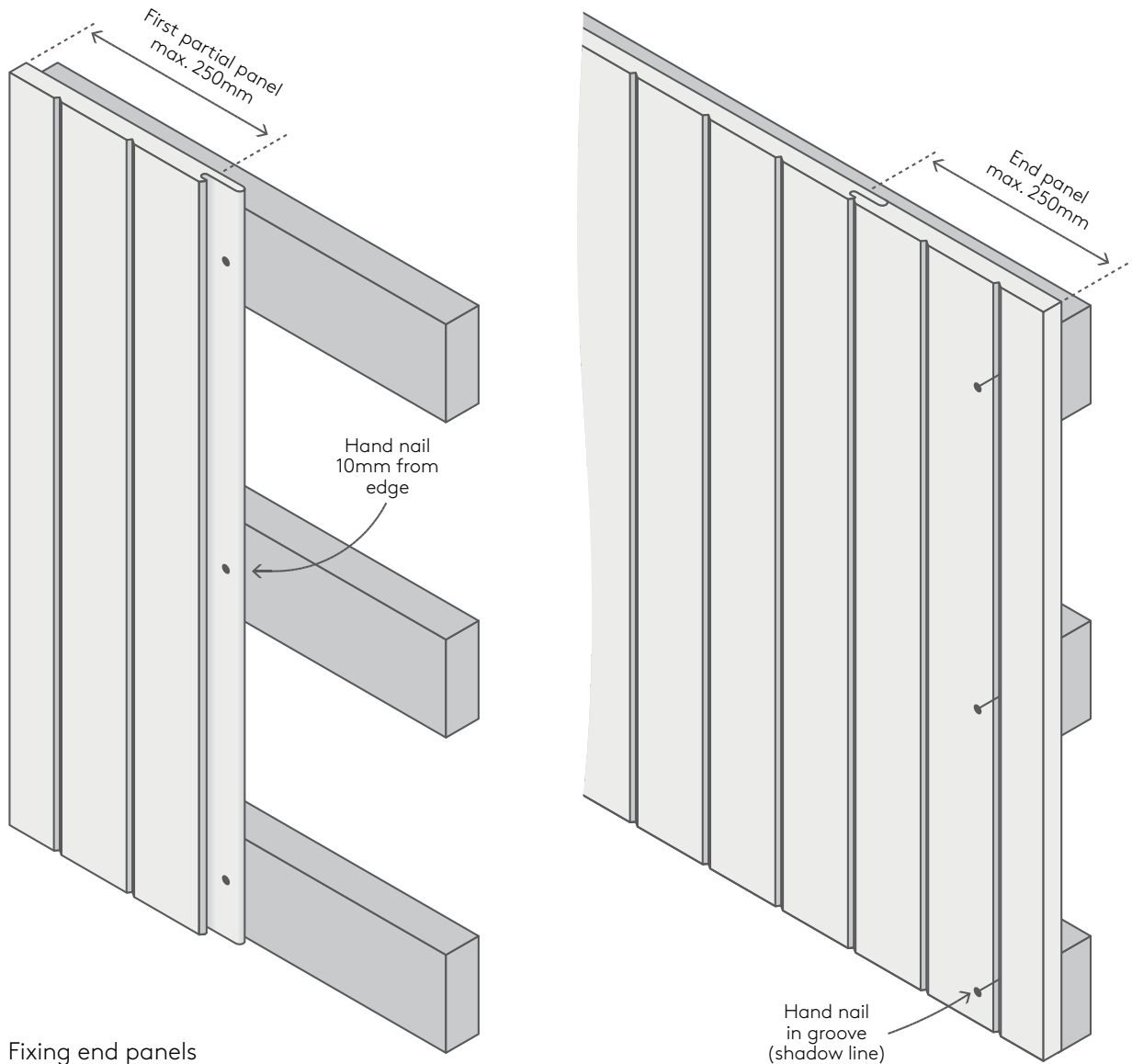

Fixing end panels

Cut the partial finishing panel to suit the remaining wall space with a maximum width of 250mm.

Apply construction adhesive as explained above.

Position the mechanical fixing at the panel's shadow line (groove) and use hand nails and a hammer to fix the panel to each batten working from the centre out or top to bottom fixing pattern.

Putty or paint can be applied to hide the nail head if required.



6.5.3 Full panel installation:

After completing the measuring steps in section 6.4, use a full-size panel to start the installation from one corner of the wall and work across.

Apply construction adhesive on each batten behind each Architectural Wall Panel. It is recommended to follow the adhesive manufacturer's instructions for the amount to be used.

Ensure there is a 10mm expansion gap at the wall-to-floor interface. Spacers can be used as a removable prop to lift the Architectural Wall Panel off the floor.

Ensure there is a 10mm expansion gap at the wall-to-ceiling interface.

Use a spirit level to ensure the Architectural Wall Panel is accurately placed onto the frame. Refer to the section 5.2 to check the wall is square and plumb.

Using nails or power-driven fasteners, fix the panels to the battens.

Position mechanical fasteners at 10mm from the edge of the Invisilock™ join of the panel on each batten working from the center out or top to bottom fixing pattern.

Remove the spacer from the bottom of the Architectural Wall Panel.

The next panel can now be placed into position using the Invisilock™ join to align the joins.

DO NOT hard knock panels together.

Fix the other panels using the same method outlined above, working along the wall from the first panel.

As you approach a corner or doorway, measure the gap from the fixed panel to the corner (effective width) and cut the next panel to fit the remaining space. It is important to maintain the expansion gap throughout.

Apply construction adhesive as explained above.

Position the mechanical fixing at the panel's shadow line (groove) and use hand nails and a hammer to fix the panel to each batten working from the centre out or top to bottom fixing pattern.

If required, position a secondary mechanical fixing at the centre shadow line (groove) and use hand nails and a hammer to fix the panel to the installed batten.

If required a nail punch can be used to sink the head of the nail just below the shadow line surface. This can then be finished with putty or paint.

Gently press the front face of the panel if movement is detected (adhesive is yet to set), additional fixing can be used.

Putty or paint can be applied to hide the nail head if required.

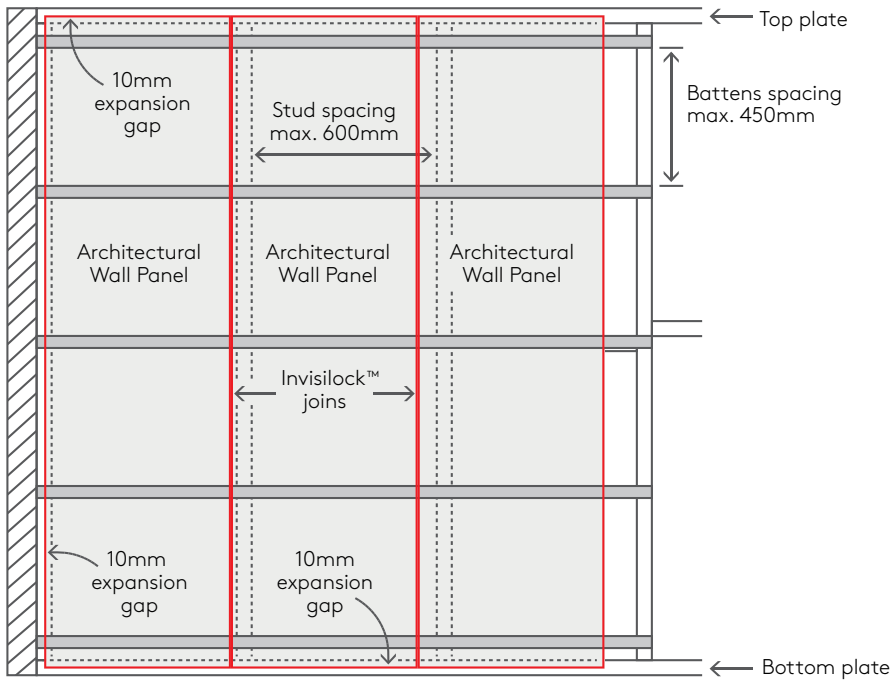

DO NOT hard knock panels together.

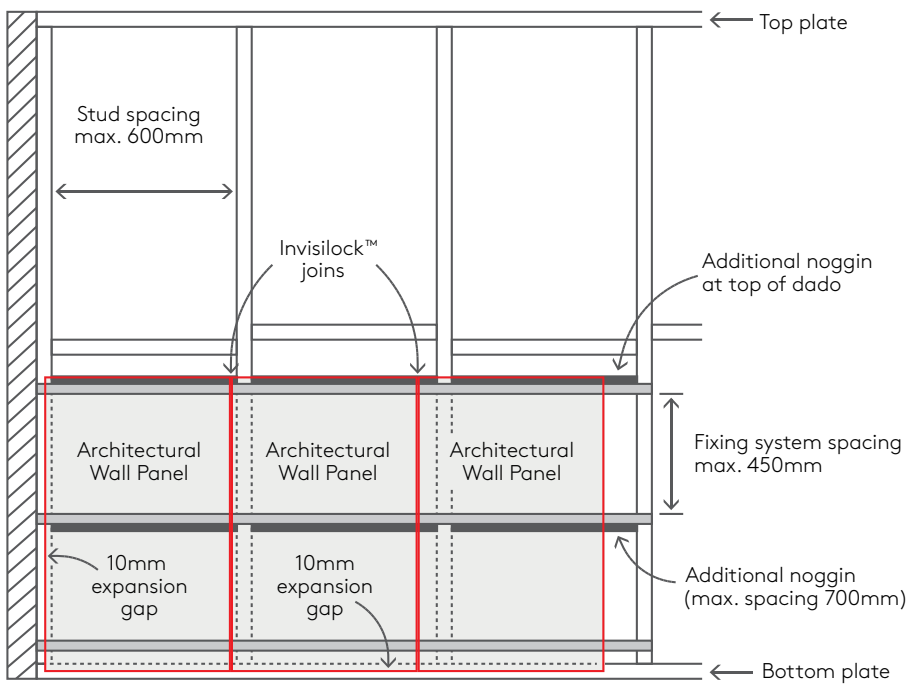

6.6 Fixing to brick and block walls or masonry

6.6.1 Preparing the wall

Z-clips, or furring channels (which are hat-shaped corrosion-resistant framing battens used to flatten and smooth out masonry wall assemblies) should be employed. Attach the fixing system to the brick or masonry wall frame using concrete nails or power-driven fasteners according to the instructions provided with the fixings.

The fixing system should be fitted horizontally at a minimum of 450mm centers to promote airflow behind the Architectural Wall Panels.



Direct fixing to brick, blockwork, or masonry is not permitted and will not be recognized under warranty.

If Architectural Wall Panels are to be used for partial wall height installations, place a batten just below the top edge of the panel for support.

Check that the fixing system is square and plumb. Refer to section 5.2 for the process.

Please refer to and comply with all expansion gap requirements.

6.6.2 Partial panel installation

After completing the measuring steps in section 6.4, cut your first partial starting panel with a max 250mm effective width to be fixed at the start of the wall.

Start from one corner/edge of the wall and work across.

Apply construction adhesive on each furring channel behind each Architectural Wall Panel. It is recommended to follow the adhesive manufacturer's instructions for the amount to be used.

Position the panel on the wall, ensure there is a 10mm expansion gap at the wall-to-floor interface.

Spacers can be used as a removable prop to lift the Architectural Wall Panel off the floor.

Ensure there is a 10mm expansion gap at the wall-to-ceiling interface.

Use a spirit level to ensure the Architectural Wall Panel is accurately placed onto the frame. Refer to section 5.2 to check the wall is square and plumb

Using screws or power-driven fasteners, fix the panels to the furring channels.

Position mechanical fasteners at 10mm from the edge of the Invisilock™ join of the panel on each furring channel working from the center out or top to bottom fixing pattern.

Remove the spacer from the bottom of the Architectural Wall Panel.

The next panel can now be placed into position using the Invisilock™ join to align the joins.

DO NOT hard knock panels together.

Fix the other panels using the same method outlined above, working along the wall from the first panel.

As you approach a corner or doorway, measure the gap from the fixed panel to the corner (effective width) and cut the next panel to fit the remaining space. It is important to maintain the expansion gap throughout.

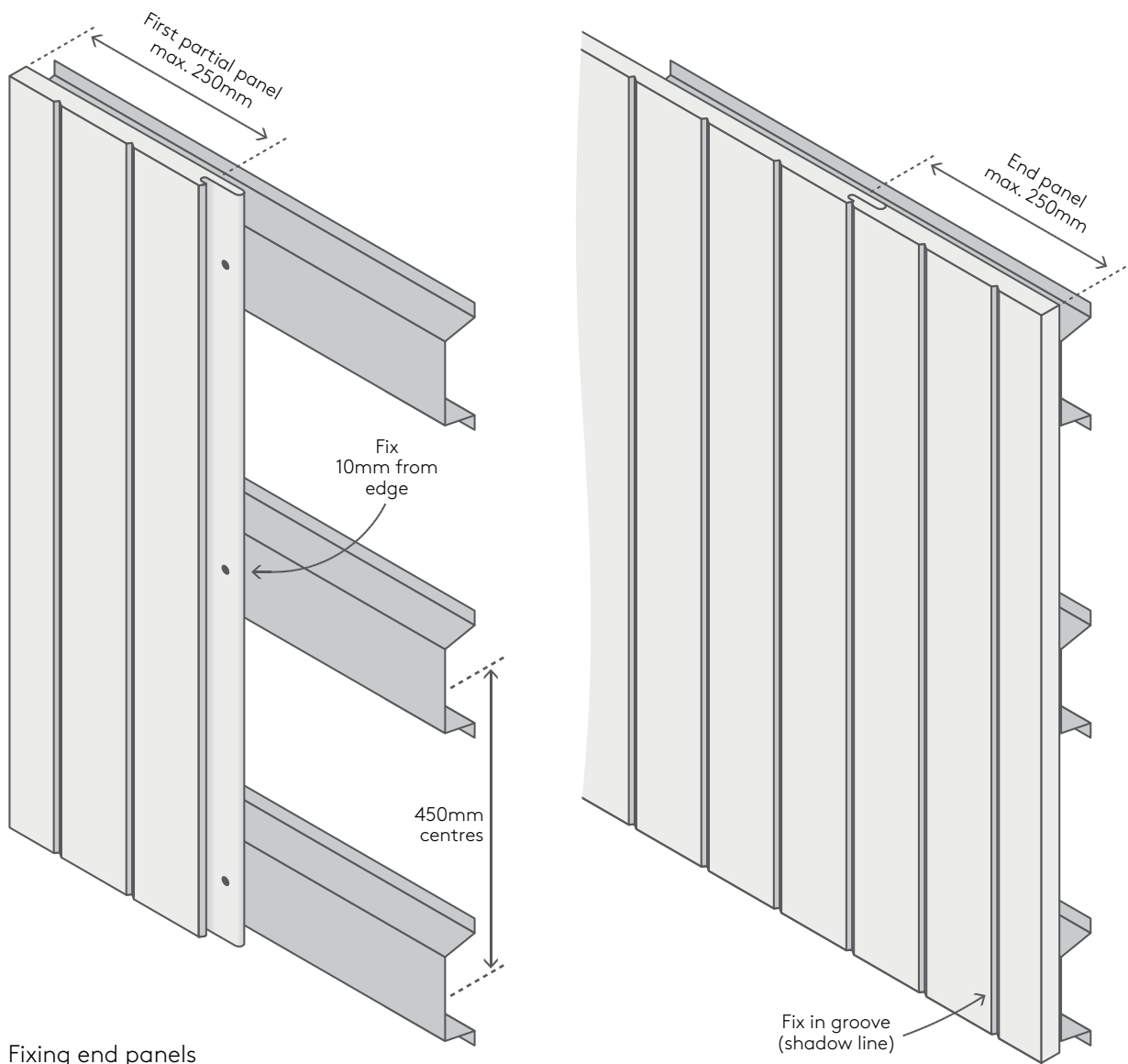

Cut the partial finishing panel to suit the remaining wall space with a maximum width of 250mm.

Apply construction adhesive as explained above and support the panel in place until the adhesive sets on the wall.

DO NOT use a power-driven screw in the groove (shadow line) as it may cause the panel to split.



6.6.3 Full Panel Installation

After completing the measuring steps in section 6.4, use a full-size panel to start the installation from one corner of the wall and work across.

Apply construction adhesive on each batten/furring channel behind each Architectural Wall Panel. It is recommended to follow the adhesive manufacturer's instructions for the amount to be used.

Ensure there is a 10mm expansion gap at the wall-to-floor interface. Spacers can be used as a removable prop to lift the Architectural Wall Panel off the floor.

Ensure there is a 10mm expansion gap at the wall-to-ceiling interface.

Use a spirit level to ensure the Architectural Wall Panel is accurately placed onto the frame. Refer to the section 5.2 to check wall to be square and plumb.

Using nails or power-driven fasteners, fix the panels to the battens or furring channels.

Position mechanical fasteners at 10mm from the edge of the Invisilock™ join of the panel on each batten or furring channel working from the center out or top to bottom fixing pattern.

Remove the spacer from the bottom of the Architectural Wall Panel.

The next panel can now be placed into position using the Invisilock™ join to align the joins.

DO NOT hard knock panels together.



Fix the other panels using the same method outlined above, working along the wall from the first panel.

As you approach a corner or doorway, measure the gap from the fixed panel to the corner (effective width) and cut the next panel to fit the remaining space. It is important to maintain the expansion gap throughout.

Fixing End Panel:

Apply construction adhesive as explained above and support the panel in place until the adhesive sets on the wall.

DO NOT use a power-driven screw in the groove (shadow line) as it may cause the panel to split. If a screw is required, a 3mm pilot hole will be required to prevent splitting. Countersunk drill bits can be employed to create a flush screw head finish.

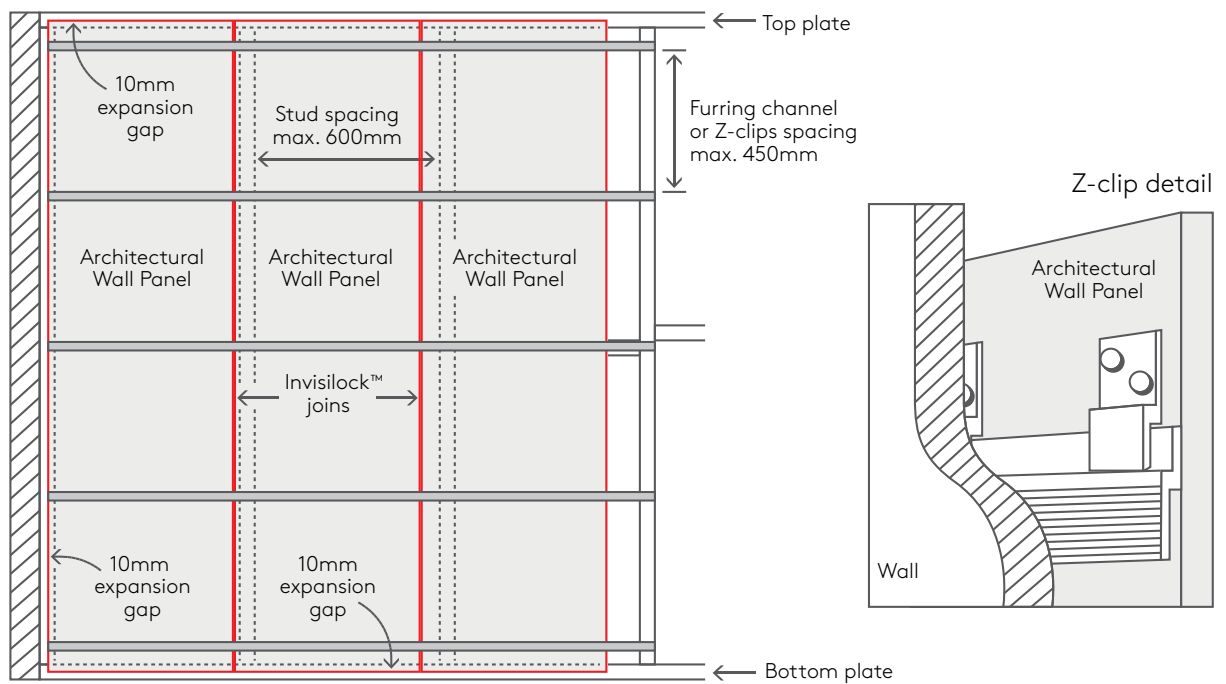

6.7 Fixing to plaster walls

6.7.1 Checking the wall

When installing the Architectural Wall Panels on an existing plaster wall, exercise caution to ensure that nails are not driven into plumbing and electrical fixtures.

The panel can be securely attached directly to plasterboard or fibre cement lining with mechanical fixing attached to the Invisilock™ join.

Follow the manufacturer's recommendations for plasterboard installation.

Check that plaster walls are square and plumb. Refer to section 5.2 for the process.

Please refer to and comply with all expansion gap requirements.

6.7.2 Partial Panel Installation

After completing the measuring steps in section 6.4, cut your first partial starting panel with a max 250mm effective width to be fixed at the start of the wall.

Start from one corner/edge of the wall and work across.

Apply construction adhesive starting with a 5mm bead around the edge of the panel (back face). Then apply an additional zigzag pattern of 5mm bead of adhesive, ensuring that the bead is within 15-20mm of the panel edge.

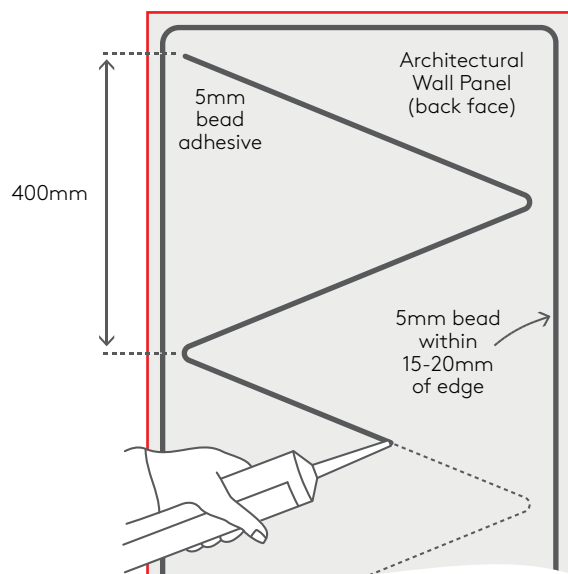

Position panel on the wall, ensure there is a 10mm expansion gap at the wall-to-floor interface.

Spacers can be used as a removable prop to lift the Architectural Wall Panel off the floor.

Ensure there is a 10mm expansion gap at the wall-to-ceiling interface.

Use a spirit level to ensure the Architectural Wall Panel is accurately placed onto the wall. Refer to the section 5.2 to check wall is square and plumb.

Position the mechanical fixing at 10mm from the edge of Invisilock™ join of the panel and using nails or power-driven fasteners, fix the panel to the plaster/fibre cement lining at the top and bottom plate of the stud wall frame.

When fixing full height Architectural Wall Panel, position the mechanical fastener at the Invisilock™ join of the panel working from a top to bottom fixing pattern or vice versa. Using this fixing pattern, the first fixing should be located at the top or bottom plate respectively. If this fixing pattern is not achievable, fix from the centre out of the Invisilock™ join.

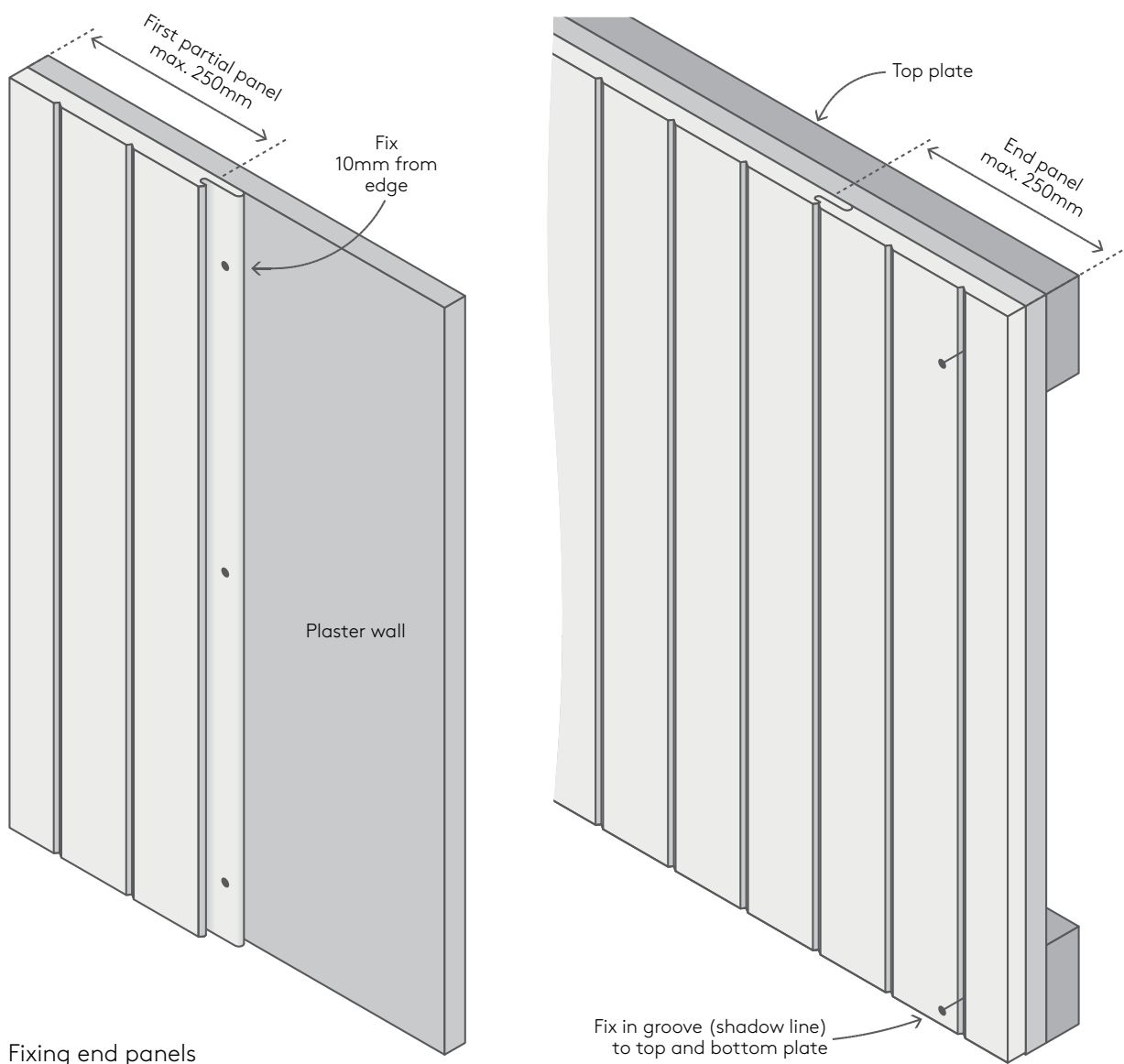

Remove the spacer from the bottom of the Architectural Wall Panel.

Continue fixing full-size panels from the partial starting panel until you reach the remaining section of the wall. The next panel can now be placed into position using the Invisilock™ join to align the joins.



DO NOT hard knock panels together.

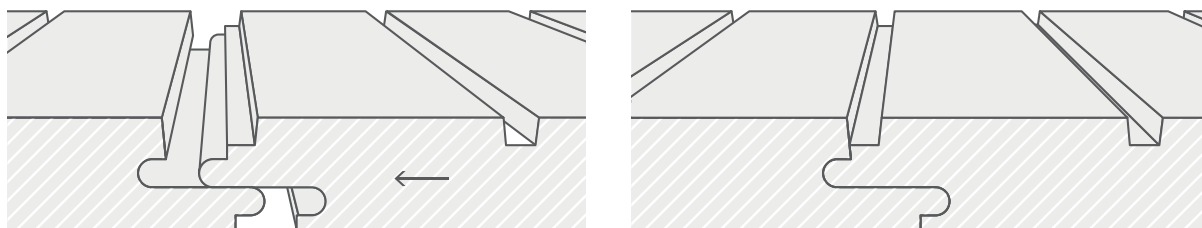

Invisilock™ Join

Fix the other panels using the same method outlined above, working along the wall from the first panel.

As you approach a corner or doorway, measure the gap from the fixed panel to the corner (effective width) and cut the next panel to fit the remaining space. It is important to maintain the expansion gap throughout.

Cut the partial finishing panel to suit the remaining wall space with a maximum width of 250mm.

Fixing End Panel:

Apply construction adhesive as explained above.

Position the mechanical fixing at the panel's shadow line (groove) and use hand nails and a hammer to fix the panel to the plaster/ fibre cement lining at the top and bottom stud wall plate.

Putty or paint can be applied to hide the nail head if required.

6.7.3 Full panel installation:

After completing the measuring steps in section 6.4, use a full-size panel to start the installation from one corner/edge of the wall and work across.

Apply construction adhesive starting with a 5mm bead around the edge of the panel (back face). Then apply an additional zigzag pattern of 5mm bead of adhesive, ensuring that the bead is within 15-20mm of the panel edge.

Position panel on the wall, ensure there is a 10mm expansion gap at the wall-to-floor interface.

Spacers can be used as a removable prop to lift the Architectural Wall Panel off the floor.

Ensure there is a 10mm expansion gap at the wall-to-ceiling interface.

Use a spirit level to ensure the Architectural Wall Panel is accurately placed onto the wall. Refer to the section 5.2 to check wall is square and plumb.

Position the mechanical fixing at 10mm from the edge of Invisilock™ join of the panel and using nails or power-driven fasteners, fix the panel to the plaster/fibre cement lining at the top and bottom plate.

If required, position a secondary mechanical fixing at the centre shadow line (groove) and use hand nails and a hammer to fix the panel to the plaster/fibre cement lining at the top and bottom stud wall plate.

If required, a nail punch can be used to sink the head of the nail just below the shadow line surface. This can then be finished with putty or paint.

When fixing the full-height Architectural Wall Panel, position the mechanical fastener at the Invisilock™ join of the panel working from a top to bottom fixing pattern or vice versa. Using this fixing pattern, the first fixing should be located at the top or bottom plate respectively. If this fixing pattern is not achievable, fix from the centre out of the Invisilock™ join.

Remove the spacer from the bottom of the Architectural Wall Panel.

The next panel can now be placed into position using the Invisilock™ join to align the joins.

DO NOT hard knock panels together.

Fix the other panels using the same method outlined above, working along the wall from the first panel.

As you approach a corner or doorway, measure the gap from the last fixed panel to the corner (effective width) and cut the next panel to fit the remaining space. It is important to maintain the expansion gap throughout.



Fixing End Panel:

Apply construction adhesive as explained above

Position the mechanical fixing at the centre shadow line (groove) and use hand nails and a hammer to fix the panel to the plaster/fibre cement lining at the top and bottom stud wall plate.

Gently press the front face of the panel if movement is detected (adhesive is yet to set), additional fixing can be used

Putty or paint can be applied to hide the nail head if required.

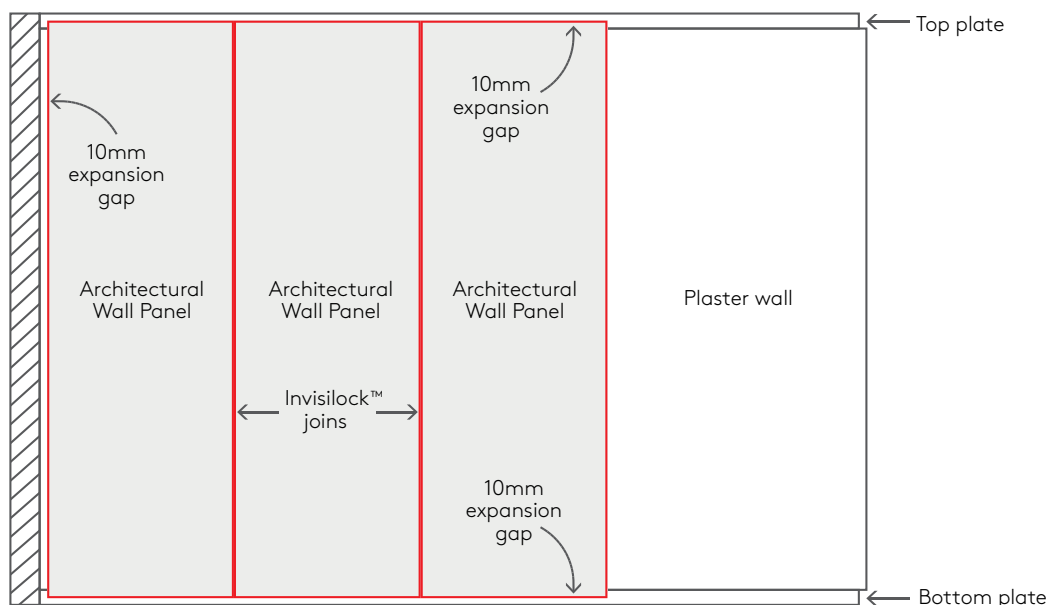

6.8 Horizontal applications of Architectural Wall Panels

Installing panels horizontally utilizes the same methods of installation for the wall substrates as described in the previous chapters with additional focus given to the following:

6.8.1 Planning join locations

The location of joins in horizontal applications for Architectural Wall Panels are more critical as these potentially need to be larger, depending upon the total length of the wall. Joining two 3000mm panels together on a 6000mm wall, leave a 10mm minimum gap between the panels and at the end of each panel, or at junctions to window and door frames.

Ensure that the profiles align correctly when installing horizontally maintaining the joining orientation.

The vertical ends of horizontally installed panels do not have the integrated joining system. An alternative form of join should be used such as expressed or negative details, or overlaid trims like dado rails can be used. The join method must allow for panel movement.

The location of the join should therefore be located centrally on the wall or place the main panel centrally to the wall.

Horizontal joins are aligned by the Invisilock™ join.

W Use of butt joints between panels ends will not be recognized under the warranty

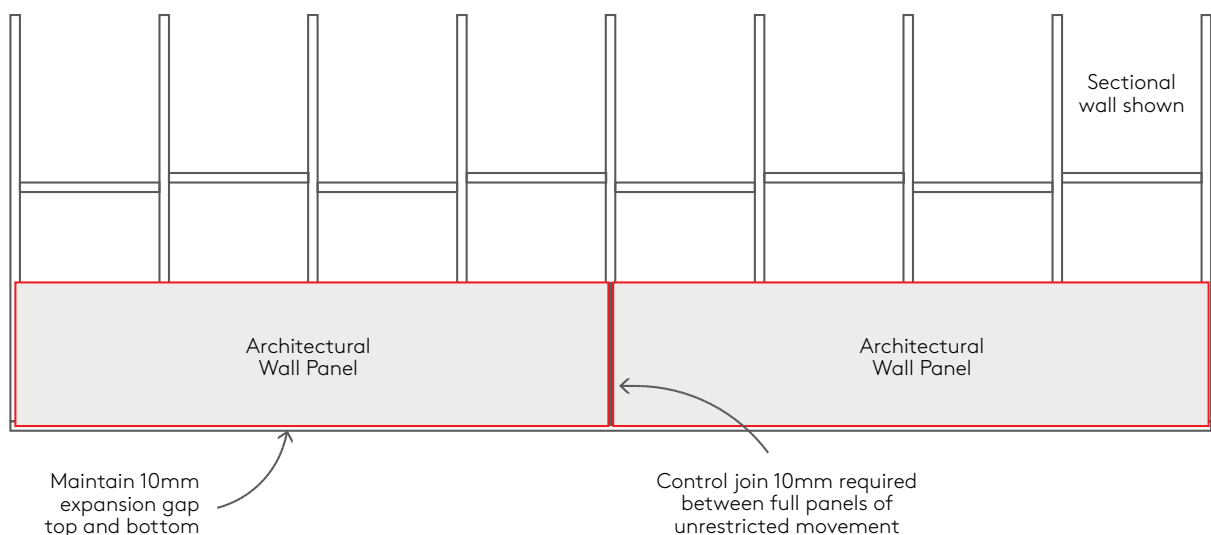

An allowance of a 5mm expansion gap between every set of 10 panels **MUST** be provided. This can be achieved using express joints or shadow lines, as needed.



6.9 Installation of Architectural Wall Panels in High Humidity & Damp Areas

DISCLAIMER: Architectural Wall Panels cannot be installed in direct 'Splash Zones'. This includes showers or any application where a vessel (bath, tapware, or basin) is within 75mm of the wall.

However, Architectural Wall Panels can be installed on all other walls within bathrooms and laundries, so long as the installation complies and is in accordance with **AS 3740:2021 Waterproofing of Domestic Wet Areas** and NCC Volume One, F1.7 and Volume Two, 3.8.1).

W Claims resulting from failure to adequately seal all exposed edges will not be recognized.

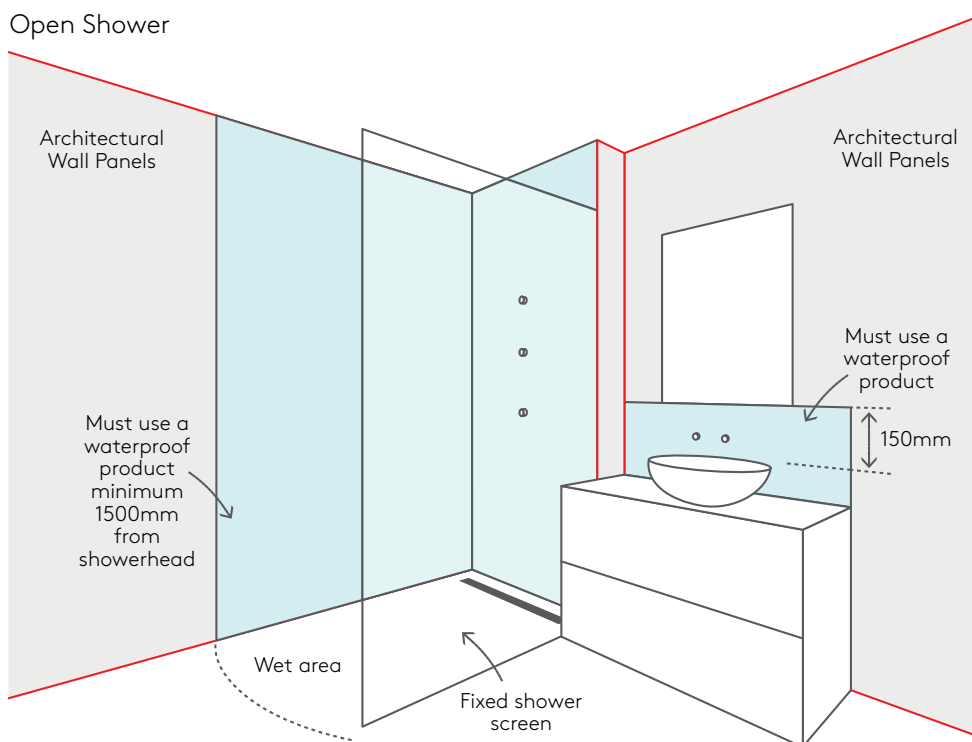

Enclosed Shower

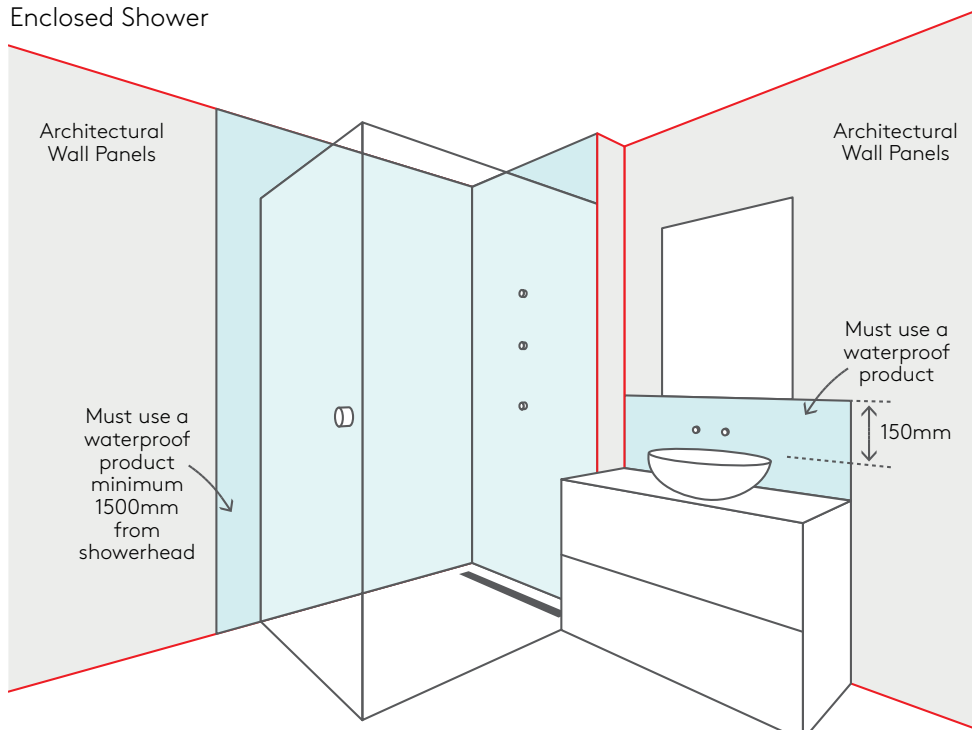

Bath — free standing

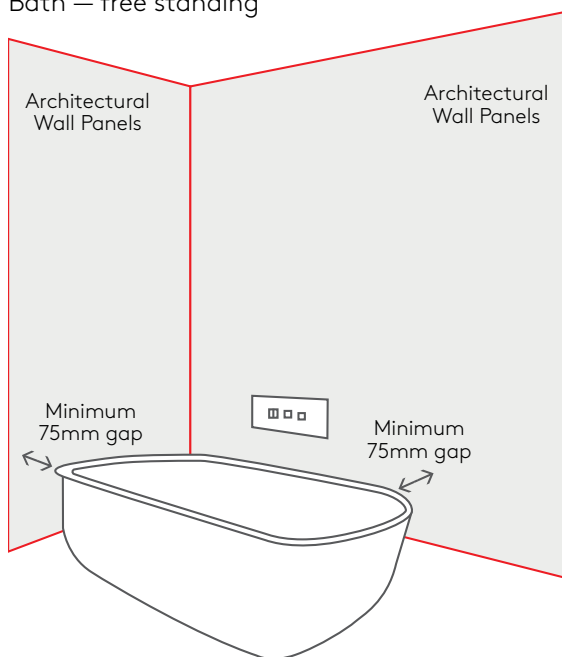

Bath — fixed

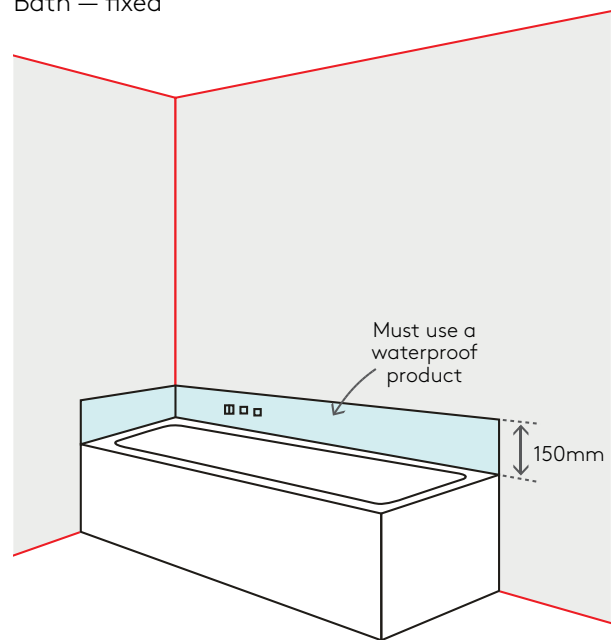

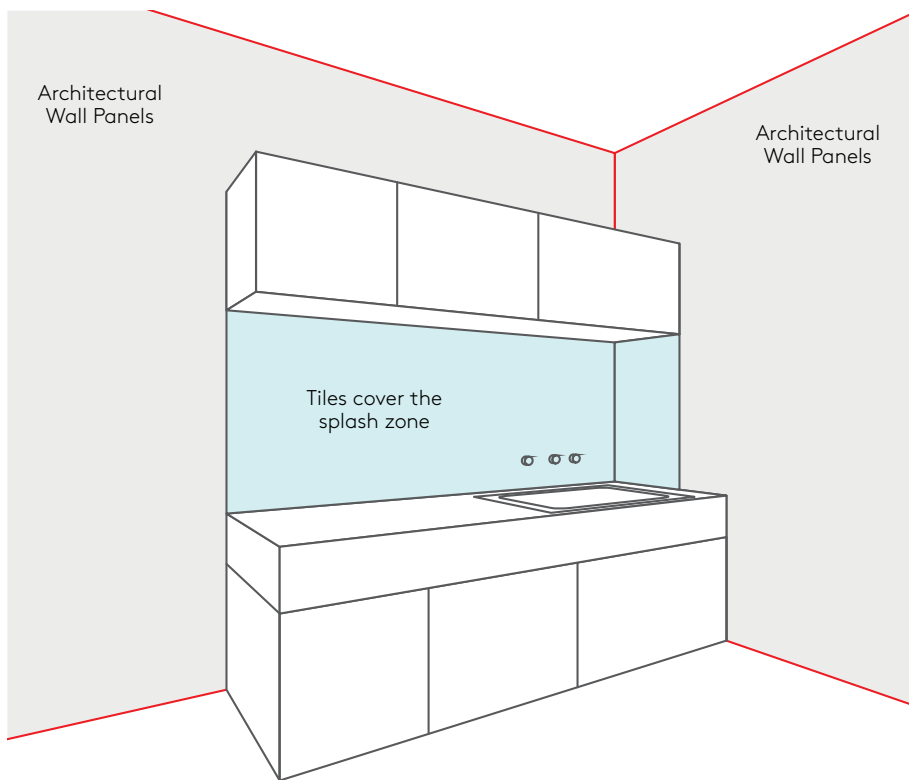
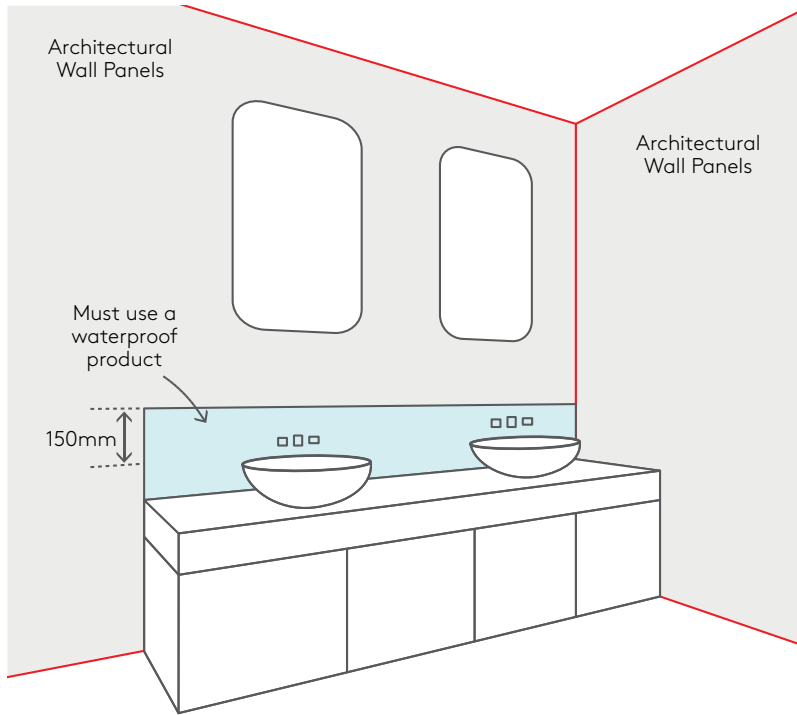

6.10 Use & fixing of dado rails and mouldings

Consider the height of your dado rail, whether it will be interrupted by architraves, windows or doors, and the optimum height to achieve an unbroken line where practical.

When using two different profiles side by side, apply a dado rail along the interface join between the profiles.

Dado rails or equivalent timber mouldings may be employed as a finishing trim:

- Along the join between any two different Architectural Wall Panel decors used together
- Where an Architectural Wall Panel finishes part way up a full-height wall
- Where the top edge of an Architectural Wall Panel may be viewed from a void or higher position in the property
- To delineate between Architectural Wall Panels and a transition to painted or textile finishes on the same wall

Various options for finished timber trims, moulding and dado or chair rails are available.

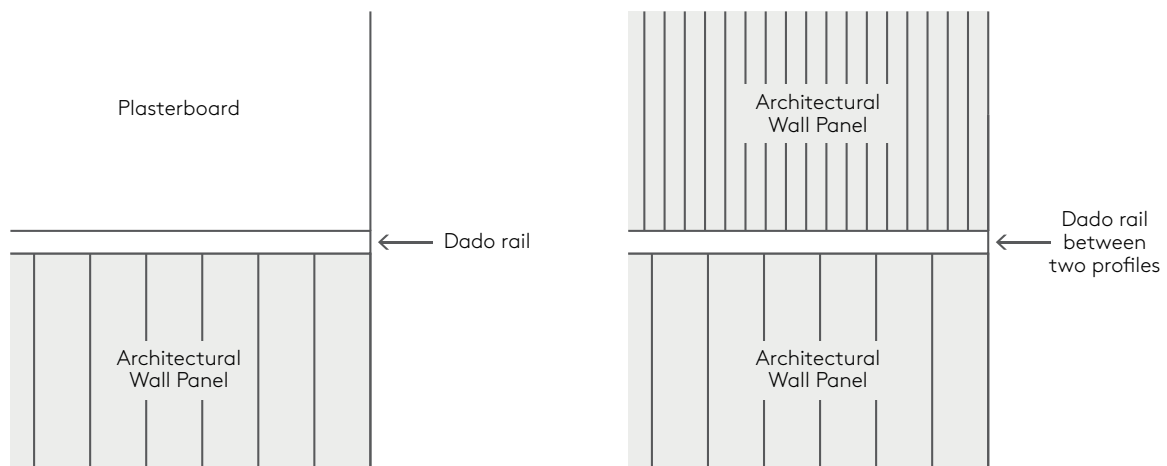

6.11 Joining System

6.11.1 Corner Joins

External Mitre Corner

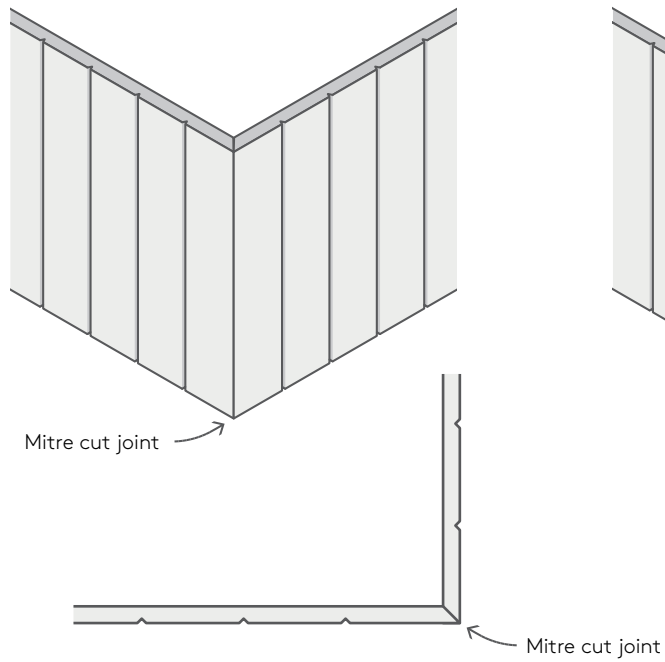

Edge Panel

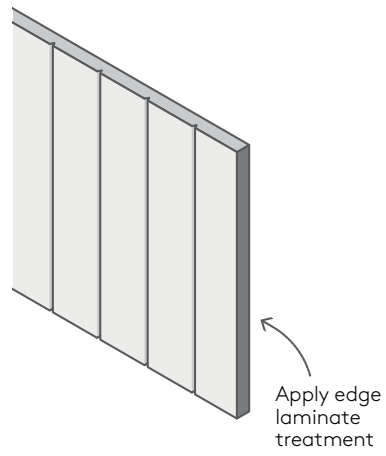

Internal Mitre Corner

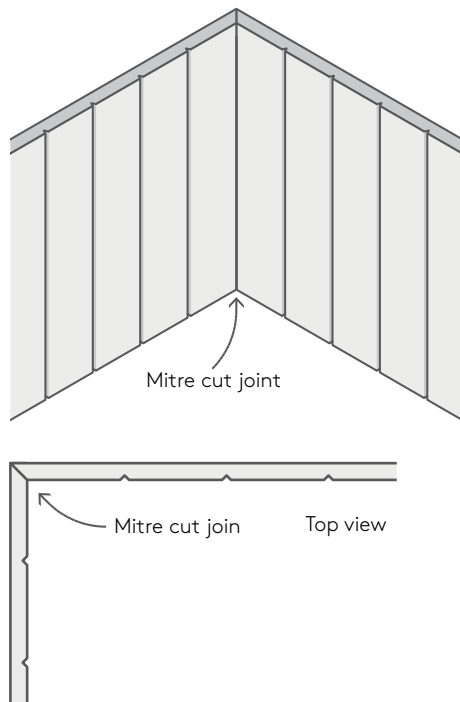

Internal Corner With Moulding

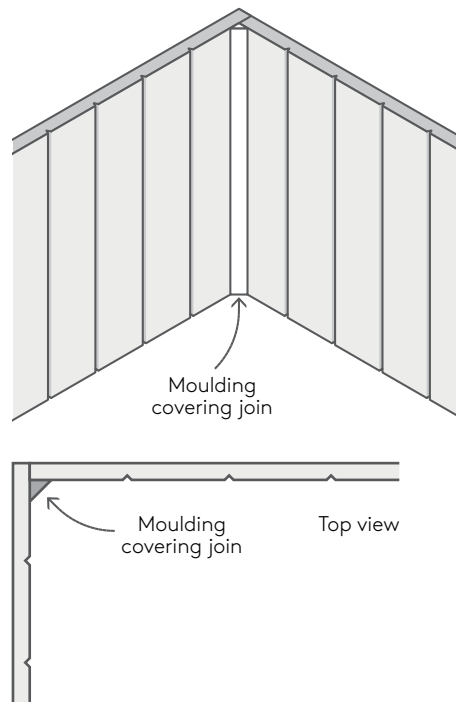

6.11.2 Corner Mouldings & Joins

When Architectural Wall Panels meet in a corner additional moulding may be required. Ensure to allow the expansion gap at the corner.

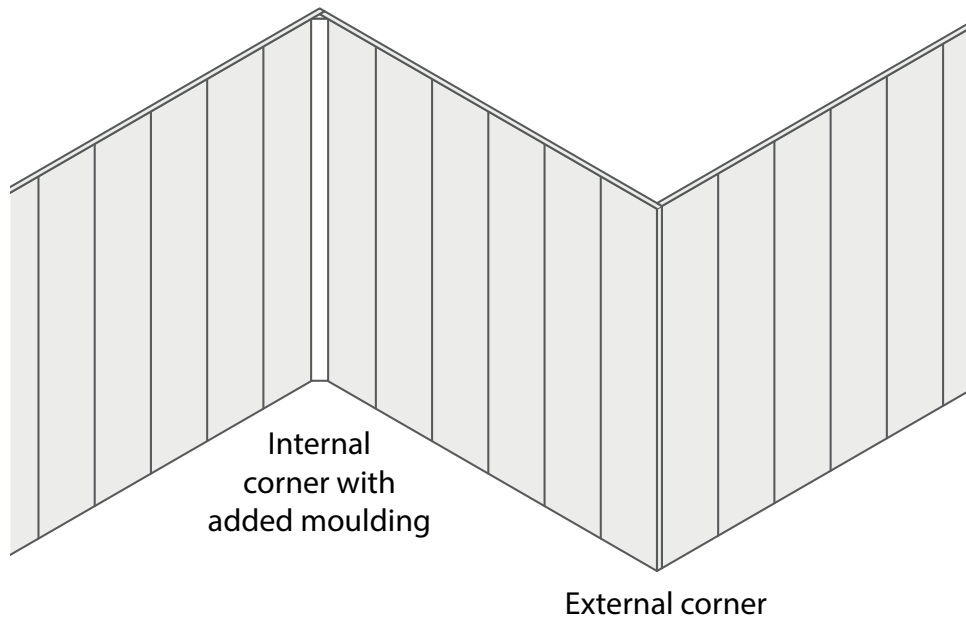

Disclaimer: Directional variations in the protective coating may affect the reflectivity of the surface. Slight shading and minor variations in the surface finish only visible at an acute angle or under critical light will not be covered under warranty. Darker decors have a greater propensity to demonstrate this contrast. This does not affect the overall performance or durability of the product

Visit us

For location of your closest showroom or more information visit laminex.com.au

Product sample

For a sample visit laminex.com.au

Call Us

For trade enquiries **132 136**

Follow Us

 facebook.com/Laminexau

 au.pinterest.com/Laminexau

 instagram.com/Laminexau

 youtube.com/Laminexau

Laminex® is manufactured, marketed and distributed by Laminex Group Pty Limited ABN 98 004 093 092, trading as Laminex.

LAM_____ | 04/24

Laminex®